

**RADIO TRANSMITTERS
T-368/URT, T-368A/URT
T-368B/URT, AND T-368C/URT
AND ANTENNA TUNING UNIT
BC-939-B
OPERATOR'S MANUAL**

This copy is a reprint which includes current
pages from Changes 1 through 5.

*DEPARTMENTS OF THE ARMY AND THE AIR FORCE
MAY 1958*

WARNING

DANGEROUS VOLTAGES EXIST IN THIS EQUIPMENT

Be careful when working on the 2,400-volt dc high-voltage circuits, or on the 115-volt ac line connections.

DON'T TAKE CHANCES

DANGEROUS RF VOLTAGES ARE EXPOSED

ON ANTENNA TUNING UNIT BC-939-B

2,400 VOLTS DC EXIST IN THE

FOLLOWING UNITS OF THE RADIO TRANSMITTER:

RF DECK

MOD DECK

HV POWER SUPPLY DECK

TM 11-809-10
TO 31R2-2URT-121
C 1

DEPARTMENT OF THE ARMY TECHNICAL MANUAL
DEPARTMENT OF THE AIR FORCE TECHNICAL ORDER

RADIO TRANSMITTERS T-368/URT, T-368A/URT, T-368B/URT, T-368C/URT, AND T-368D/URT ANTENNA TUNING UNIT BC-939-B; RADIO FREQUENCY TUNER TN-339/GR; AND STANDING WAVE RATIO-POWER METER ME-165/G

TM 11-809-10
TO 31R2-2URT-121
CHANGES No. 1

}

DEPARTMENT OF THE ARMY
AND THE AIR FORCE
WASHINGTON 25, D.C., 6 August 1959

TM 11-809-10, 14 May 1958, is changed as indicated so that the manual also applies to Radio Frequency Tuner TN-339/GR and Standing Wave Ratio-Power Meter ME-165/G.

Change the title of the manual to: **RADIO TRANSMITTERS T-368/URT, T-368A/URT, T-368B/URT, T-368C/URT, AND T-368D/URT; ANTENNA TUNING UNIT BC-939-B; RADIO FREQUENCY TUNER TN-339/GR; AND STANDING WAVE RATIO-POWER METER ME-165/G; OPERATOR'S MANUAL.**

Change "Antenna Tuning Unit BC-939-B" to read: "Antenna Tuning Unit BC-939-B or Radio Frequency Tuner TN 339/GR" in the following places:

Page 3, paragraph 1a, line 6.

Paragraph 3c, line 1.

Page 4, paragraph 4g, line 5.

Page 30, paragraph 17f, heading.

Page 38, appendix, line 3.

After "T-368C/URT" add "and T-368D/URT" in the following places:

Page 3, paragraph 1d, line 6.

Page 7, paragraph 7e, line 18; paragraph 9c, line 8.

Page 8, paragraph 10, line 2.

Page 3, paragraph 1a, line 4. Insert the following after the first sentence: Operation and operator's maintenance of Standing Wave Ratio-Power Meter ME-165/G and Radio Frequency Tuner TN-339/GR (fig. 1.1) are also covered.

Line 7. After the second sentence, add: Standing Wave Ratio-Power Meter ME-165/G is called the matching unit.

Paragraph 3. Add the following after subparagraph c.

d. The matching unit is connected between the transmitter and its load, which may be either the

doublet transmitting antenna or the antenna tuning unit connected to a long-wire or whip antenna. The matching unit provides a non-inductive dummy load of 52 ohms and permits direct readings of the transmitter power output and the standing wave ratio (SWR) between the transmitter and its load.

Page 4, paragraph 4. Add the following to subparagraph g: The matching unit helps in tuning the transmitter for maximum transfer of energy to the antenna system. The fixed impedance of the integral dummy load protects the transmitter circuitry during tuning procedures.

Page 5, figure 2. Add a block designated "MATCHING UNIT" between the "TRANSMITTER" and "ANTENNA TUNING UNIT" blocks.

Page 7, paragraph 7e, line 6 from bottom of page. After "(fig. 1)" add: or Radio Frequency Tuner TN-339/GR (fig. 1.1).

Add paragraph 8.1 after paragraph 8.

8.1. Description of Matching Unit

(fig.1.1)

All components of the matching unit are mounted on the front panel, which fastens into a louvered case by means of 10 screws. The rear of the case is provided with a flange on top and a bracket on the bottom to permit wall mounting. A wing nut on the bottom of the case secures a ground braid. The unit is 1 1/4 inches by 9 inches by 9 inches and has a gray, smooth finish.

Page 9, paragraph 10. Change heading of "C model" column to: **C and D models.** "C and D models" column, eighth item. Change "TUNE-NORMAL switch" to: **TUNE-NORMAL on Order No. 28459-Phila-55, TUNE-OPERATE on all other orders.**

Add paragraph 10.1 after paragraph 10.

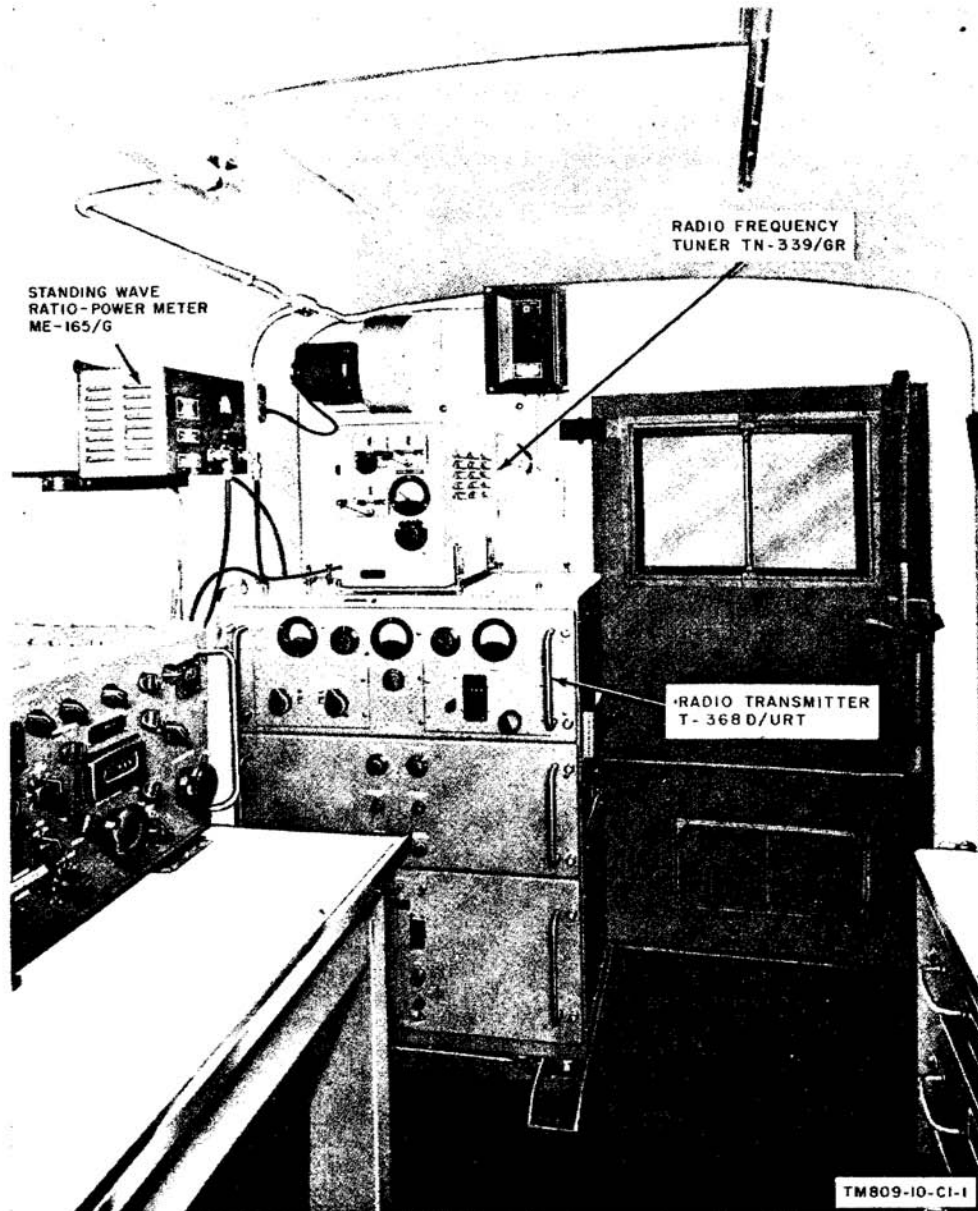

Figure 1.1 (Added) Radio Transmitter T-568D/URT with Radio Frequency Tuner TN-559/GR and Standing Wave Ratio Power Meter ME-165/G

TAGO 715A

10.1 Differences in Antenna Tuning Units

Radio Frequency Tuner TN-339/GR differs from Antenna Tuning Unit BC-939-B in that coupling coil L5 consists of a greater number of turns of wire. This provides optimum SWORE characteristics over the frequency range. The mechanical counter associated with the COU-PLING control indicates three digits to correspond to the greater tuning variation.

Page 11, paragraph 12c, "Control or instrument" column, fourth item. Change "A and C" to: **A and some C.**

Page 12. Add paragraph 13.1 after paragraph 13.

13.1. Matching Unit

(fig. 7.1)

Control or instrument	Function										
Control switch	The positions of the switch and the corresponding functions are as follows: <table border="1" style="margin-left: 20px;"> <thead> <tr> <th>Position</th> <th>Function</th> </tr> </thead> <tbody> <tr> <td>POWER</td> <td>Connects transmitter power to dummy load. Power output of the transmitter is indicated on the meter.</td> </tr> <tr> <td>ADJUST</td> <td>Permits calibration of the meter.</td> </tr> <tr> <td>SWR</td> <td>Standing wave ratio between the transmitter and its load is indicated on the meter.</td> </tr> <tr> <td>OPERATE</td> <td>Connects the transmitter output directly to the load.</td> </tr> </tbody> </table>	Position	Function	POWER	Connects transmitter power to dummy load. Power output of the transmitter is indicated on the meter.	ADJUST	Permits calibration of the meter.	SWR	Standing wave ratio between the transmitter and its load is indicated on the meter.	OPERATE	Connects the transmitter output directly to the load.
Position	Function										
POWER	Connects transmitter power to dummy load. Power output of the transmitter is indicated on the meter.										
ADJUST	Permits calibration of the meter.										
SWR	Standing wave ratio between the transmitter and its load is indicated on the meter.										
OPERATE	Connects the transmitter output directly to the load.										
ADJUST control meter	Calibrates meter for SWR reading. Depending on the position of the control switch, indicates SWR on upper scale from 0 to 1.5:1 (green area); from 1.5:1 to 2:1 (white area); and higher (red area) Indicates transmitter power output in watts on the lower scale										

Page 15, paragraph 14b. Make the following changes:

Subparagraph (1), line 3. After "(fig. 5)", add: or, if a matching unit is used, to the **OUTPUT** terminal of the matching unit.

TAGO 715A

Subparagraph (2), line 1. After "unit", add: (without a matching unit).

Subparagraph (2). Add the following after subparagraph (2):

- (3) When the matching unit is used with the antenna tuning units, check the following
 - (a) Rf cable between the matching unit OUTPUT connections.
 - (b) Rf cable between tile R. F. OUTPUT receptacle of the transmitter (fig. 5) and the INPUT connector of the matching unit (fig. 7.1) .connector (fig. 7.1) and the input terminals on the side of the tuning unit.
 - (c) Ground braid from wing nut on matching unit to grounding strip.
 - (d) Lead from the antenna terminal on the rear of the tuning unit to the longwire or whip antenna.

Page 17, paragraph 15. Add the following after subparagraph b:

c. *Radio Frequency Tuner TN-339/GR.* Control settings for Radio Frequency Tuner TN339/GR when used with the transmitter and Standing Wave Ratio-Power Meter ME-165/G are given below.

(1) 2- to 10-mc range.

Operating frequency (mc)	COUPLING control setting	Loading (FREQUENCY control. 2 MC to 10 MC)
2.00	5.8	6.9
2.05	5.7	9.2
2.10	5.6	11.3
2.15	5.5	13.3
2.20	5.3	15.2
2.25	5.2	16.9
2.30	5.2	18.5
2.35	5.1	20.0
2.40	5.0	21.4
2.45	4.9	22.7
2.50	4.8	24.0
2.55	4.7	25.2
2.60	4.6	26.3
2.65	4.5	27.4
2.70	4.5	28.4
2.75	4.5	29.4
2.80	4.4	30.3
2.85	4.4	31.2
2.90	4.3	32.0
2.95	4.2	32.8
3.00	4.2	33.5
3.05	4.2	34.3
3.10	4.1	35.0
3.15	4.1	35.6
3.20	4.0	36.3

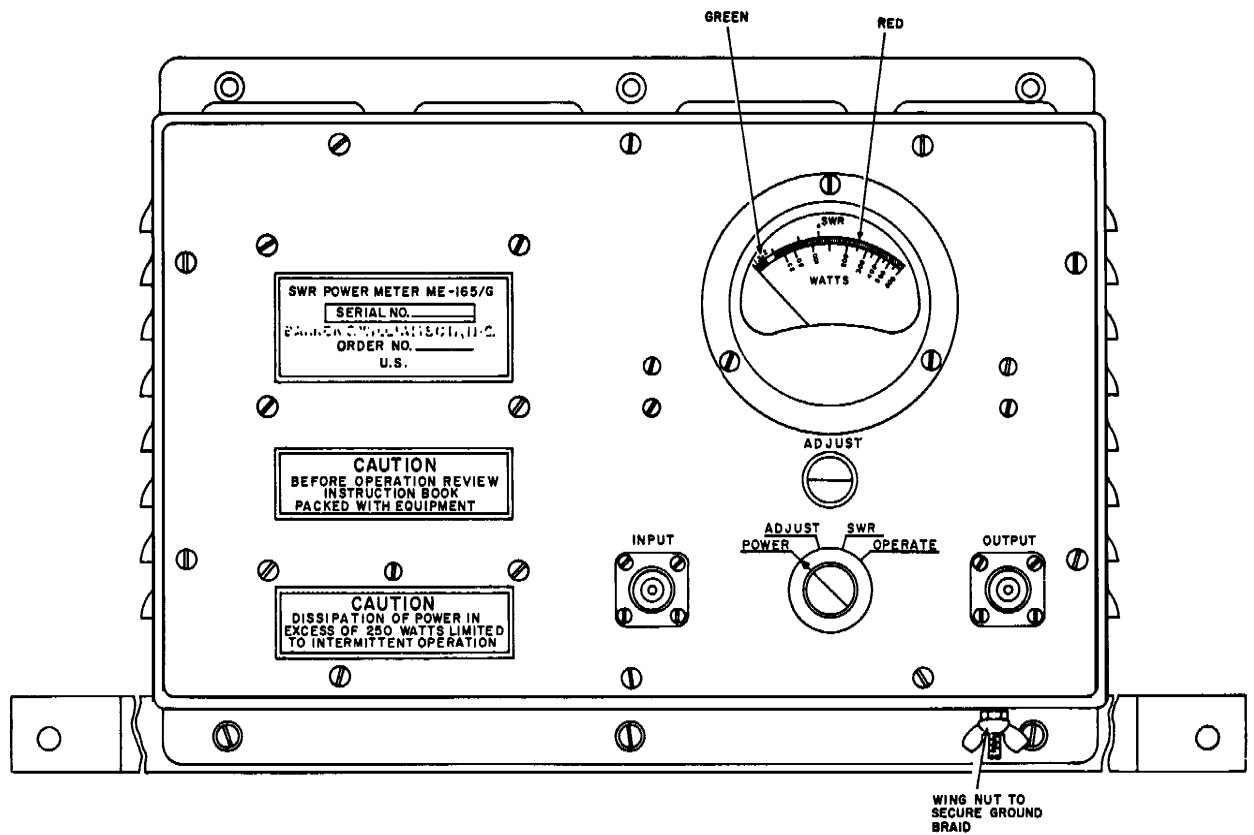

TAGO 715A

TM809-10-C1-2

Figure 7.1. (Added) Matching unit front panel.

TAGO 715A

Operating frequency (mc)	COUPLING control setting	Loading (FREQUENCY control, 2 MC to 10 MC)
3.25	4.0	36.9
3.30	4.0	37.5
3.35	4.0	38.0
3.40	3.9	38.5
3.45	3.8	39.1
3.50	3.8	39.6
3.55	3.8	40.1
3.60	3.8	40.5
3.65	3.8	41.0
3.70	3.8	41.4
3.75	3.7	41.8
3.80	3.7	42.2
3.85	3.6	42.6
3.90	3.6	43.0
3.95	3.6	43.4
4.00	3.6	43.7
4.05	3.6	44.1
4.10	3.6	44.4
4.15	3.5	44.7
4.20	3.5	45.0
4.25	3.5	45.3
4.30	3.5	45.6
4.35	3.5	45.9
4.40	3.5	46.2
4.45	3.5	46.4
4.50	3.4	46.7
4.55	3.4	47.0
4.60	3.4	47.2
4.65	3.4	47.4
4.70	3.4	47.7
4.75	3.4	47.9
4.80	3.4	48.1
4.85	3.4	48.3
4.90	3.4	48.5
4.95	3.4	48.8
5.00	3.2	48.9
5.05	3.2	49.1
5.10	3.2	49.3
5.15	3.2	49.5
5.20	3.2	49.7
5.25	3.2	49.9
5.30	3.1	50.1
5.35	3.1	50.2
5.40	3.1	50.4
5.45	3.1	50.5
5.50	3.1	50.7
6.55	3.1	50.9
5.60	3.1	51.0
5.65	3.1	51.2
5.70	3.1	51.3
5.75	3.2	51.5
5.80	3.2	51.6
5.85	3.2	51.8
5.90	3.2	51.9
5.95	3.2	52.0
6.00	3.2	52.2
6.05	3.2	52.3
6.10	3.2	52.4
6.15	3.2	52.5

Operating frequency (mc)	COUPLING control setting	Loading (FREQUENCY control, 2 MC to 10 MC)
6.20	3.2	52.7
6.25	3.3	52.8
6.30	3.3	52.9
6.35	3.3	53.1
6.4	3.3	53.2
6.5	3.3	53.4
6.6	3.3	53.6
6.7	3.3	53.8
6.8	3.4	54.0
6.9	3.4	54.2
7.0	3.4	54.4
7.1	3.4	54.5
7.2	3.3	54.7
7.3	3.3	54.9
7.4	3.3	55.1
7.5	3.3	55.2
7.6	3.3	55.4
7.7	3.2	55.6
7.8	3.2	55.7
7.9	3.2	55.9
8.0	3.2	56.0
8.1	3.2	56.2
8.2	3.2	56.3
8.3	3.2	56.5
8.4	3.2	56.6
8.5	3.2	56.8
8.6	3.2	57.0
8.7	3.2	57.1
8.8	3.2	57.3
8.9	3.2	57.4
9.0	3.2	57.5
9.1	3.2	57.7
9.2	3.2	57.8
9.3	3.2	58.0
9.4	3.2	58.2
9.5	3.2	58.3
9.6	3.2	58.5
9.7	3.2	58.6
9.8	3.2	58.8
9.9	3.2	59.0
10.0	3.2	59.2

(2) 10- to 20-mc range.

Operating frequency	COUPLING control setting	Loading(FREQUENCY control, 2 MC to 10 MC)
10.0	2.9	1.4
10.1	2.9	1.7
10.2	2.9	2.0
10.3	2.9	2.4
10.4	2.9	2.7
10.5	3.0	3.0
10.6	3.0	3.4
10.7	3.0	3.7
10.8	3.0	4.0
10.9	3.0	4.3
11.0	3.0	4.6

Operating frequency (mc)	COUPLING control setting	Loading (FREQUENCY control, 10 MC to 20 MC)
11.1	3.0	5.0
11.2	3.0	5.2
11.3	3.1	5.5
11.4	3.1	5.9
11.5	3.1	6.1
11.6	3.1	6.4
11.7	3.1	6.7
11.8	3.1	7.0
11.9	3.2	7.2
12.0	3.2	7.5
12.1	3.2	7.7
12.2	3.2	8.0
12.3	3.2	8.2
12.4	3.2	8.5
12.5	3.2	8.7
12.6	3.2	8.9
12.7	3.3	9.1
12.8	3.3	9.4
12.9	3.3	9.6
13.0	3.3	9.8
13.1	3.3	10.0
13.2	3.4	10.2
13.3	3.4	10.4
13.4	3.4	10.6
13.5	3.4	10.8
13.6	3.5	11.0
13.7	3.5	11.2
13.8	3.6	11.5
13.9	3.6	11.6
14.0	3.7	11.8
14.2	3.8	12.2
14.4	4.0	12.6
14.6	4.0	12.9
14.8	4.2	13.3
15.0	4.4	13.6
15.2	4.5	14.0
15.4	4.9	14.3
15.6	5.4	14.6
15.8	5.8	14.8
16.0	6.6	14.9
16.2	7.6	14.8
16.4	8.9	14.6
16.6	9.4	14.5
16.8	9.5	14.4
17.0	9.5	14.4
17.2	9.2	14.5
17.4	7.7	14.8
17.6	7.5	15.0
17.8	6.8	15.2
18.0	6.7	15.3
18.2	6.6	15.3
18.4	6.5	15.3
18.6	6.4	15.4
18.8	6.0	15.5
19.0	5.5	15.6
19.2	5.2	15.7
19.4	4.6	15.9

Operating frequency (mc)	COUPLING control setting	Loading (FREQUENCY control, 10 MC to 20 MC)
19.6	4.4	16.0
19.8	4.3	16.0
20.0	4.3	16.2

Page 28, paragraph 16c, line 2. After "B" add: D, and some C. Add the following after subparagraph e:

f. Set the control switch of the matching unit to the POWER position.

Page 29, paragraph 17. Make the following changes:

Subparagraph a(17), line 3. Change "A and C" to **A and some C.**

Subparagraph e. Delete subparagraph e and substitute:

e. *FSK-AM Tuning.*

- (1) Follow instructions given in a (1) through (8) above except that in a(5), set the SERVICE SELECTOR switch to the FSK position.
- (2) Tune the external fsk exciter in accordance with its technical manual. Set the exciter frequency in accordance with instructions given in d above.
- (3) Set the KEYING switch to tile CONTINUOUS position (EXCITER PLATE POWER switch in the up position in the basic model).
- (4) Adjust the TUNING CONTROL for a maximum reading on the EXCITATION meter (8 ma minimum). Adjust the fsk exciter output for an EXCITATION meter reading between 8 and 12 ma.
- (5) Follow instructions given in a(11) through (16) above.
- (6) Set the SERVICE SELECTOR switch to the FSK-AM position.
- (7) Follow the am tuning procedures given in b(1) (c) through (4) above.

Subparagraph f. Add the following note below the warning:

Note. Use these procedures only when no Stand in Wave Ratio-Power Meter ME-165/G is used. When a matching unit is provided, follow procedures given in g below.

TAGO 715A

Subparagraph *f* (1). Delete subparagraph (e) (f), and (g) end substitute:

- (e) Follow the cw tuning procedures given in a(9) through (13) above.

Note. Do not readjust the POWER AMPLIFIER LOADING control after the initial setting is made in accordance with the power amplifier loading chart.

- (f) Adjust the COUPLING and FREQUENCY controls of the tuning unit for maximum ANTENNA CURRENT meter indication with 150 milliamperes on the P A PLATE meter.
- (g) Throw the TUNE-OPERATE switch to OPERATE (TUNE-NORMAL) switch to NORMAL in A model and in C model transmitters procured on Order No. 28459-Phila-55). The P A PLATE meter should read approximately 350 ma (275 ma in AM). If it does not, readjust the COUPLING and FREQUENCY controls until a maximum indication is obtained on the ANTENNA CURRENT meter.
- (h) (Added) Check to see if any adjustment of the POWER AMPLIFIER TUNING control results in an increase in the P A PLATE meter indication. If the P A PLATE meter can be dipped, readjust the COUPLING and FREQUENCY controls until the 350-ma reading is obtained on the P A PLATE meter and maximum rf current is indicated on the ANTENNA CURRENT meter.

Note. At low frequencies, 350 ma P A PLATE current may not be obtained. *Do not attempt to increase the maximum reading obtainable by adjusting the POWER AMPLIFIER LOADING control.*

- (i) (Added) Turn the EXCITATION METER switch to the INT AMP PLATE X 10 position. The EXCITATION meter reading should be between 20 and 70 ma.

Page 31, paragraph 17. Add the following after subparagraph (f)

g. Tuning Procedure for Standing Wave Ratio-Power Meter ME-165/G (fig. 7.1).

Caution: If the transmitting antennas of two or more radio sets are close together, coordinate tuning operations so that one set is not transmitting while the

control switch of the matching unit in the other set is in the SWR position. Power radiated from a nearby radio set antenna can burn out the dummy load resistors in the matching unit.

(1) *With the tuning unit and whip or longwire antenna:*

- (a) Check to see that the matching unit control switch is in the POWER position.
- (b) Tune and- load the transmitter, following the procedures given in a above. Note that the lower scale of the matching unit meter indicates the transmitter power output.

Caution: When the matching unit control switch is in the POWER, ADJUST, or SWR position, full transmitter output is dissipated in the dummy load of the matching unit. Do not apply power continuously for longer than 10 minutes. The matching unit can be damaged by the great amount of heat generated.

- (c) Set the matching unit control switch to the ADJUST position and rotate the ADJUST control to obtain a full scale meter reading. Do not keep the switch in the ADJUST position any longer than necessary for meter adjustment.
- (d) Set the matching unit control switch to the SWR position. The standing wave ratio between the transmitter and the tuning unit may now be read on the upper scale of the meter.
- (e) When using a whip antenna, set the tuning unit COUPLING and FREQUENCY controls to the settings (par. 15b, Antenna Tuning Unit BC-939-B; par. 15c Radio Frequency Tuner TN-339/GR) for the desired frequency. When using a long-wire antenna, set the COUPLING control at about 2.0 and set the range switch at LONG WIRE. Adjust the tuning unit for a minimum SWR reading (in the green area). Final dial settings of the tuning unit may differ slightly from those given in the chart, because of the effect of nearby objects such as trees, buildings, or wires on antenna characteristics.

Note. If the minimum SWR is 1.5:1 or higher, check for loose connections and make certain that the roller contacts in the tuning unit are clean. At frequencies above 17 mc, it a 1:1 SWR cannot be obtained, remove the top antenna section and re-tune.

- (f) Set the matching unit control switch to OPERATE. This connects the output of the transmitter directly to the tuning unit. Minor readjustment of the transmitter POWER AMPLIFIER TUNING and LOADING controls may be necessary to obtain a P A PLATE meter reading of 350 ma.

Note. Optimum tuning of the tuning unit as indicated by the matching unit may not result in a maximum reading on the tuning unit ANTENNA CURRENT meter. Maximum meter reading does not necessarily indicate maximum power transfer to the antenna.

(2) *With doublet antenna:*

- (a) Tune and load the transmitter; follow the procedures given in *a* above.
- (b) Set the control switch of the matching unit to ADJUST and set the ADJUST control for a full-scale meter reading.

[AG 413.44 (24 Jul 59)]

- (c) Set the control switch of the matching unit to SWR and read the standing wave ratio. It should be in the green area, but may be as high at 2:1. If the meter reads above 2, check for loose or broken connections in the antenna lead and make certain that the antenna is not touching trees, wires, or other obstructions. If the meter still reads above 2, the antenna must be lengthened or shortened.

Note. The SWR cannot be corrected by adjusting the transmitter. The SWR can only be improved by correcting the antenna length for the operating frequency. Formulas for antenna length are based on average conditions. The antenna length may be different from calculated length because of ground conditions, antenna height, or proximity of trees and structures.

- (d) Set the matching unit control switch to OPERATE. This connects the output of the transmitter directly to the doublet antenna. Minor readjustment of the transmitter POWER AMPLIFIER TUNING and LOADING controls may be necessary to obtain a P A PLATE meter reading of 350 ma.

Page 32 paragraph 24. Add the following sentence: For standby operation, the matching unit control switch may be left in tile OPERATE position; otherwise set the control switch to the POWER position.

By Order of *Wilber M. Brucker*, Secretary of the Army:

L. L. LEMNITZER,
General, United States Army,
Chief of Staff.

OFFICIAL

R. V. LEE,
Major General, United States Army,
The Adjutant General.

THOMAS D. WHITE,
Chief of Staff, United States Air Force.

OFFICIAL :

J. L. TARR,
Colonel, United States Air Force,
Director of Administrative Services.

Distribution:

Active Army:

USASA (2)	Gen Dep (2) except Atlanta Gen	Sector Comd, USA Corps	
Def ^r Atomic Spt Agcy (5)	Dep (none)	(Res) (1)	
CNGB (1)	Sig Sec. Gen Dep (10)	Mil Msn (2)	
Tech Stf, DA (1) except	Sig Dep (17)	JBUSMC (2)	
CSigO (18)	Army Pictorial Cen (2)	Units organized under following	
Tech Stf Bd (1)	USA Sp Warfare Cen (5)	TOE's:	
USA Arty Bd (1)	Engr Maint Cen (1)	5-500 (AA-	11-500 (AA-
USA Armor Bd (1)	USA Ord Msl Comd (3)	AD) (2)	AE) (2)
USA Inf Bd (1)	USASSA (15)	6-545 (2)	11-537 (2)
USA AD Bd (1)	USASSAMRO (1)	7-52 (2)	11-557 (2)
USA Abn & Elct Bd (1)	USA Sig Pub Agcy (8)	9-22 (2)	11-587 (2)
USA Avn Bd (1)	USA Sig Engr Agcy (1)	9-86 (2)	11-592 (2)
USA ATB (1)	USA Comm Agcy (2)	11-5 (2)	11-597 (2)
USCONARC (5)	USA Sig Eqp Spt Agcy (7)	11-7 (2)	17-51 (2)
US ARADCOM (2)	USA Sig Msl Spt Agcy (13)	11-15 (2)	17-55 (2)
US ARADCOM Rgn (2)	WRAMC (1)	11-16 (2)	20-45 (2)
OS Maj Comd (5)	AFIP (1)	11-17 (2)	20-46 (2)
OSBase Comd (5)	AMS (1)	11-18 (2)	20-300 (2)
Log Comd (5)	Ports of Emb (OS) (2)	11-37 (2)	32-51 (2)
MDW (1)	Trans Terminal Comd (1)	11-39 (2)	32-55 (2)
Armies (5) except	Army Terminals (1)	11-55 (2)	32-56 (2)
First US Army (7)	OS Sup Agcy (1)	11-57 (2)	32-500 (2)
Corps (2)	Yuma Test Sta (2)	11-85 (2)	39-51 (2)
Div (2)	USA Elct PG (1)	11-87 (2)	39-61 (2)
USATC (2)	Sig Lab (5)	11-95 (2)	39-71 (2)
Svc Colleges (5)	Sig Fld Maint Shops (3)	11-98 (2)	44-12 (2)
Br. Svc Sch (5) except	Mil Dist (1)	11-99 (2)	44-101 (2)
USASCS (25)	USA Corps (Rea)(1)	11-117 (2)	44-536 (2)
		11-155 (2)	

NG: State AG (3); units--save as Active Army except allowance is one copy to each unit.

USAR: None.

For explanation of abbreviations used, see AR 320-50.

Operator's Manual

RADIO TRANSMITTERS T-368/URT, T-368A/URT, T-368B/URT, T-368C/URT, T-368D/
URT, AND T-368E/URT; ANTENNA TUNING UNIT BC-939-B; RADIO FREQUENCY
TUNER TN-339/GR; AND STANDING WAVE RATIO-POWER METER ME-165/G

TM-11-809-10 }
TO 31R2-2URT-121 }
CHANGES No. 2 }

DEPARTMENTS OF THE ARMY,
AND THE AIR FORCE,
WASHINGTON 25, D.C., 27 September 1960

TM 11-809-10/TO 31R2-2URT-121, 14 May 1958, is changed as indicated so that the manual also applies to Radio Transmitter T-368E/URT and Standing Wave Ratio-Power Meter ME-165/G procured on Orders No. 3219-PP-59 and 3241-PP-59.

Paragraph 10.1 (page 3 of C1)
Add paragraph 10.2 after paragraph 10.1.

Change the title of the manual to: **Operator's Manual, Radio Transmitters T-368/URT, T-368A/URT, T-368B/URT, T-368C/URT, T-368D/URT, and T-368E/URT; ANTENNA TUNING UNIT BC-939-B; RADIO FREQUENCY TUNER TN-339/GR; AND STANDING WAVE RATIO-POWER METER ME-165/G.**

10.2 Differences in Matching Units

Standing Wave Ratio-Power Meter ME-165/G, shown in figure 7.1, indicates power on the lower meter scale and standing wave ratio on the upper meter scale; those procured on Order Numbers 3219-PP-59 and 3241-PP-59 indicate power on the upper meter scale and SWR on the lower scale.

Note. Parenthetical reference to previous changes (example "page 1 of C 1") indicates that pertinent material was published in that Changes. Add "and T-368E/URT" after "T-368D/URT" in the following places:

- Page 3, paragraph 1d (page 1 of C 1), line 6.
- Page 7, paragraph 7e (page 1 of C 1), line 18.
- Paragraph 9c (page 1 of C 1), line 8.
- Page 8, paragraph 10. Delete and substitute:

Page 12, paragraph 13.1 (page 3 of C 1). Make the following changes in the Control or instrument column, second item, delete "meter." Add Meter as separate item under "ADJUST control." Function column, third item: line 2. Change "indicates SWR on upper scale" to: indicates standing wave ratio on SWR scale. Line v, change "on the lower scale" to: on the WATTS scale.

Page 14, figure 7.1 (page 4 of C 1). Add the following note:

10. Differences in Transmitters

All models of the transmitter are similar in purpose, operation, and appearance. The only differences that affect operation are in switch labeling (para. 12b and 12c). Switch S12 is labeled TUNE-OPERATE in all models except A-model transmitters and C-model transmitters procured on Order No. 28459-Phila-55. On these transmitters the switch is labeled TUNE-NORMAL. Switch S6 is labeled EXCITER PLATE POWER on the unlettered-model transmitter. It has an OFF position and ON (up) position. On all lettered-model transmitters, it is labeled KEYING. The two positions of the switch are labeled NORMAL and CONTINUOUS.

NOTE:

METER SCALES SHOWN ARE REVERSED ON SOME MODELS; THE WATTS SCALE IS ON TOP AND THE SWR SCALE IS ON THE BOTTOM.

Page 28, paragraph 16c. Delete subparagraph c and substitute:

c. Set the TUNE-OPERATE switch (TUNE-NORMAL in the A and some C models) to the TUNE position.

Page 31, paragraph 17G, (page 7 of C 1).

Subparagraph (1) (b), line 3. Change "lower" to: WATTS.

Subparagraph (1)(d),line5. Change "upper" to: SWR.

BY ORDER OF THE SECRETARIES OF THE ARMY AND THE AIR FORCE:

L. L. LEMNITZER,
*General, United States Army,
Chief of Staff.*

OFFICIAL:

R. V. LEE,
*Major General, United States Army,
The Adjutant General.*

THOMAS D. WHITE,
Chief of Staff, United States Air Force

OFFICIAL:

"T. L. TARR,
*Colonel, United State, Air Force,
Director of Administrative Services.*

DISTRIBUTION:

Active Army: To be distributed in accordance with DA Form 12-7 requirements for TM 11 Series (Uncl) plus the following:

USASA (2)	11-15 (2)	11-592 (2)
Def Atomic Spt Agcy (5)	11-16 (2)	11-597 (2)
CNGB (1)	11-17 (2)	17-51 (2)
Tech Stf, DA (1)	11-18 (2)	17-55 (2)
except CSigO (18)	11-37 (2)	20-45 (2)
US ARADCOM (2)	11-38 (2)	20-46 (2)
US ARADCOM Rgn (2)	11-39 (2)	29-56 (2)
MDW (1)	11-55 (2)	32-51 (2)
Seventh US Army (2)	11-57 (2)	32-56 (2)
EUSA (2)	11-85 (2)	32-57 (2)
Div (2)	11-87 (2)	32-500 (2)
Units organized under following	11-95 (2)	39-51 (2)
TOE's:	11-98 (2)	39-61 (2)
6-501 (2)	11-99 (2)	39-71 (2)
7-52 (2)	11-117 (2)	39-401 (2)
9-22 (2)	11-155 (2)	44 12 (2)
9-86 (2)	11-500 (AA-AE) (2)	44 101 (2)
11-5 (2)	11-557 (2)	
11-7 (2)	11-587 (2)	

NG: State AD (3); units same as Active Army except allowance is one copy to each unit.

USAR: None.

For explanation of abbreviations used, see AR 320-50.

Operator's Manual

RADIO TRANSMITTERS T-368/URT, T-368A/URT, T-368B/URT,
T-368C/URT, T-368D/URT, AND T-368E/URT
ANTENNA TUNING UNIT BC-939B; RADIO FREQUENCY TUNER TN 339/GR; AND
STANDING WAVE RATIO-POWER METER ME-165/G

TM 11-809-10
TO 31R2-2URT-121
CHANCES No. 3

}

DEPARTMENTS OF THE ARMY
AND THE AIR FORCE
WASHINGTON 25, D.C. 12 April 1961

TM 11-809-10/TO 31R2-2URT-121, 14 May 1958 is changed as follows:

Page 3, paragraph 1. Delete subparagraphs c and e.
Paragraph 2.

d. *Parts List Form.* (Added) Forward DA Form 2028 (Recommended Changes to DA Technical Manual Parts Lists or Supply Manual 7, 8, or 9) direct to the Commanding Officer, U.S. Army Signal Materiel Support Agency, ATTN: SIGMS-ML, Fort Monmouth, N.J., with comments on parts listings in appendix II.

e. *Comments on Manual.* (Added) Forward all other comments on this publication direct to the Commanding Officer, U.S. Army Signal Materiel Support Agency, ATTN: SIGMS-PA2d, Fort Monmouth, N.J.

Page 28 (also page 6 of C 1). Delete paragraph 17 and substitute:

17. Tuning Procedure

(fig.6)

Refer to paragraph 16 for preliminary power control settings before using the tuning procedure.

Caution: Do not operate an unloaded transmitter; serious damage to the equipment will result.

a. *Cw Tuning Procedure.*

- (1) Set the TUNING CONTROL to indicate the desired frequency. Figure 18 shows two positions of the TUNING CONTROL dial. The 1.5-3.0-mc position uses four digits and reads 1.920 mc, The

6.0-12.0-mc position uses five digits and reads 11.350 mc, The 3.0-6.0-mc and 12.0-20.0-mc positions also use four and five digits, respectively. When the BAND SELECTOR switch is set in the two lower bands, the fourth digit reads either 0 or 5; when the switch is set in the two upper bands, the fourth digit travels through 0 to 9, and the fifth digit remains at 0. When the frequency to be used does not fall on the exact number (1.917 or 11.357 mc, for example), interpolation must be used. The transmitter therefore must be calibrated as shown in (14) below.

- (2) Set the POWER AMPLIFIER TUNING control to the number that corresponds to the desired frequency (para. 15a.).
- (3) Set the POWER AMPLIFIER LOADING control to about 28 on the indicator dial; this is minimum loading.
Note. Approach this setting carefully so as not to damage the stop mechanism.
- (4) Turn the BAND SELECTOR switch to the desired band.
- (5) Turn the PA BAND SWITCH to the desired band.

*These changes supersede TM 11-5820-258- 101', 1 August 1958.

material issued as part of the major end item. All items authorized for basic operator maintenance of the equipment are also listed.

- (2) The organizational maintenance repair parts and special tools list lists repair parts authorized for organizational , maintenance and is a basis for requisitioning by organizations which are authorized the major item of equipment. End items of equipments are issued on the basis of allowances prescribed in equipment authorization tables and other documents that are a basis for requisitioning.
- (3) The maintenance allocation chart assigns maintenance functions and repair operations to be performed by the lowest appropriate maintenance echelon.

b. Columns are as follows:

- (1) *Source, maintenance, and recoverability code.* Not used.
- (2) *Federal stock number.* This column lists the 11-digit Federal stock number.
- (3) *Designations by model.* Not used.
- (4) *Description.* Nomenclature or the standard item name and brief identifying data for each item are listed in this column. When requisitioning, enter the nomenclature and description.
- (5) *Unit of issue.* The unit of issue is each, not annotated, and is the supply term by which the individual item is counted for procurement, storage, requisitioning, allowances, and issue purposes.
- (6) *Expendability.* Nonexpendable items are indicated by NX; expendable items are not annotated.
- (7) *Quantity incorporated in unit.* This column lists the quantity of each part found in a given assembly, component, or equipment.
- (8) *Organizational.* See paragraph 3.
- (9) *Quantity authorized* Under "Item Comprising an Operable Equipment," the column lists the quantity of items supplied for the initial

operation of the equipment. Under "Running Spares and Accessory Items," the quantities listed are those issued initially with the equipment as spare parts. The quantities are authorized to be kept on hand by the operator for maintenance of the equipment.

(10) *Illustrations.* Not used.

2. Parts for Maintenance

When this equipment is used by signal service organizations organic to the theater headquarters or communication zones to provide theater communications, those repair parts authorized up to and including fourth echelon are authorized for stockage by the organization operating this equipment.

3. Repair Parts Authorization

An asterisk (*) in the column titled "15 Day Maintenance Allowance per 100 Equipments" indicates that an item is not authorized for stockage but if required, may be requisitioned for immediate use only.

4. Other Service Stock Numbers

Other service items listed herein are authorized in accordance with AR 700-51.

5. References

Additional instructions concerning maintenance of this equipment are contained in TM 11-6115-202-10P, Basic Issue Items List, Generator Set, Gasoline Engine PU-286/G and power Unit PE-197. TM 116115-202-20P, Organizational Maintenance Repair Parts and Special Tools List and Maintenance Allocation Chart, Generator Set, Gasoline Engine PU-286/C and Power Unit PE-197.

6. Comments or Suggestions

Any comments concerning omissions and discrepancies in this manual will be prepared on DA Form 2028 and forwarded direct to Commanding Officer, U.S. Army Signal Materiel Support Agency, ATTN: SIGMSML, Fort Monmouth, N. J.

(21) Throw the TUNE-OPERATE switch to OPERATE (TUNE-NORMAL switch to NORMAL in A and C models) .

(a) P A PLATE meter should read approximately 350 ma. If not, repeat the procedures in (17) and (20) above until 350 ma is obtained. Make these adjustments as rapidly as possible to avoid damage to the power amplifier tube or other components.

Note. For the procedures in (17) through (21) above. the numbers of the tuning controls may be changed so that they do not fall in approximate center of the shaded areas of the calibration charts. This is permissible as long as the numbers remain inside the shaded areas.

(b) The EXCITATION meter should indicate a reading of 8 to 12 ma at P A GRID X2 position.

(c) Turn the EXCITATION METER SWITCH to the INT AMP PLATE X10 position; the EXCITATION meter reading should be between 20 and 70 ma.

Caution: Be sure that 70 ma is not exceeded, because the life of the intermediate power amplifier (ma) tube will be reduced considerably.

(d) The FIL VOLTAGE meter should read 5 to 5.2 volts. If not. readjust the FILAMENT VOLTAGE control until it does.

(e) The power output should be approximately 450 watts on the POWER scale of the matching unit meter.

Note. This reading shows the amount of power dissipated in the dummy load in the matching unit.

(f) Set the matching unit control switch to the ADJUST position and rotate the ADJUST control to obtain a full-scale reading. Do not keep the switch in the ADJUST position any longer than necessary for meter adjustment.

***Caution:* When the matching unit control switch is in the POWER, ADJUST, or SWR position, full transmitter output is dissipated in the dummy load of the matching unit. Do not apply power continuously for longer than**

10 minutes. The matching unit can be damaged by the great amount of heat generated.

(g) Set the matching unit control switch to the SWR position. The standing wave ratio between the transmitter and load may now be read on the meter. (Some matching units have the meter scales reversed.) The meter reading should fall within the green area. If an SWR reading of 1.5:1 or higher is obtained, *dip* the SWR meter reading by slowly rocking the FREQUENCY control on the tuning unit. If an SWR reading of 1.5:1 or lower cannot be obtained on a whip or long wire antenna, shut off the equipment (par. 24) and check the antenna connections and the roller contacts in the tuning unit.

***Caution:* If the transmitting antennas of two or more radio sets are close together, coordinate the tuning operations so that one set is not transmitting while the control switch of the matching unit in the other set is in the SWR position. Power radiated from a nearby antenna can burn out some of the resistors in the matching unit.**

Note. When a whip antenna is used, if the minimum SWR is 1.5 :1 or higher at frequencies above 17mc, remove one antenna section and retune.

(h) If a doublet antenna is being used, the SWR reading may be as high as 2 : 1; this is permissible. A slight readjustment of the POWER AMPLIFIER LOADING controls may be necessary to obtain maximum power output with a plate current reading not to exceed 350 ma with the plate circuit in resonance. If a reading higher than 2:1 is still obtained turn the transmitter off (par. 24), check for loose connections, and be sure that the antenna is not touching trees, wires, or other obstructions. If, after this check, the reading is still

SECTION III. SECOND ECHELON FUNCTIONAL PARTS LIST

(1) SOURCE MAINTENANCE AND RECOVERABILITY CODE				(2) FEDERAL STOCK NUMBER	(3) DESIGNATION BY MODEL				(4) DESCRIPTION	(5) UNIT OF ISSUE	(6) EXP	(7) QTY INC IN UNIT	(8) ORGANI- ZATIONAL 15 DAYS MAINTENANCE ALLOWANCE PER 100 EQUIPMENTS	(9) (10) LLUSTRATIONS		
													2 ND	FIG NO	ITEM NO	
									GENERATOR SET GROUP OA-1675/GRC							
				5820-543-1282					GENERATOR SET GROUP OA-1675/GRC		NX					
				5935-284-3965					CAP AND CHAIN ASSEMBLY MK-1143/U			2	*			
									DRUMS, GASOLINE: inflammable liquid gasoline; w/carrying handle; 5 gal cap; Ord dwg No. 08456Z (QM Stk No. 42-D-1280)			5	*			
				5975-224-5260					GROUND ROD MX-148/G: SigC dwg No. SC-D-14158			1	*			
				8130-711-0537					REEL, CABLE RC-405/TB: SigC dwg No. Sc-d-68149			1	*			
				6115-305-5259					SPOUTS, GASOLINE: flexible nozzle; Ord dwg No. 09153W			1	*			

75/GRC

2

SECTION IV

MAINTENANCE ALLOCATION

7. General

a. Functions and repair operations to be performed by the lowest appropriate maintenance echelon.

b. Columns in the maintenance allocation chart are as follows:

- (1) *Part or component.* This column shows only the nomenclature or standard item name. Additional descriptive data are included only where clarification is necessary to identify the part. Components and parts comprising a major end item are listed alphabetically. Assemblies and subassemblies are in alphabetical sequence with their components listed alphabetically immediately below the assembly listing.
- (2) *Maintenance function.* This column indicates the various maintenance functions allocated to the echelon capable of performing the operations.
 - (a) *Service.* To clean, to preserve, and to replenish fuel and lubricants.
 - (b) *Adjust.* To regulate periodically to prevent malfunction.
 - (c) *Inspect.* To verify serviceability and to detect incipient electrical or mechanical failure by scrutiny.
 - (d) *Test.* To verify serviceability and to detect incipient electrical or mechanical failure by use of special equipment such as gages, meters, etc.
 - (e) *Replace.* To substitute service assemblies, subassemblies, and parts for unserviceable components.
 - (f) *Repair.* To restore an item to serviceable condition through correction of a specific failure or unserviceable condition. This function includes but is not limited to,

inspecting, cleaning, pre-serving, adjusting, replacing, welding, riveting, and straightening.

- (g) *Align.* To adjust two or more components of an electrical system so that their functions are properly synchronized.
 - (h) *Calibrate.* To determine, check, or rectify the graduation of an instrument, weapon, or weapons system, or components of a weapons system.
 - (i) *Rebuild.* To restore an item to a standard as near as possible to original or new condition in appearance, performance, and life expectancy. This is accomplished through the maintenance technique of complete disassembly of the item, inspection of all parts or components, repair or replacement of worn or unserviceable elements using original manufacturing tolerances and/or specifications and subsequent reassembly of the item.
 - (j) *Overhaul.* To restore an item to completely serviceable condition as prescribed by serviceability standards developed and published by heads of technical services. This is accomplished through employment of the technique of "Inspect and Repair Only as Necessary" (IROAN). Maximum utilization of diagnostic and test equipment is combined with minimum disassembly of the item during the overhaul process.
- (3) *1st, 2d, 3d, 4th, 5th echelon.* The symbol X indicates the echelon responsible for performing that particular maintenance operation, but supplied for the initial

operation of the equipment. Under "running spares and accessory items, "the quantities listed are those issued initially with the equipment as spare parts. The quantities are authorized to be kept on hand by the operator for maintenance of the equipment.

- (8) *Illustrations.* The "item No." column lists the reference designations that appear on the part in the equipment. These same designations are used on any illustrations of the equipment.

2. Critical Items

A zero slash (Ø) in the "description" column indicates items that are expected to fail during the first year, or items that will make the equipment inoperative if they fail.

3. Other Service Stock Numbers

Other service items listed herein are authorized in accordance with AR 700-51.

SECTION II. FUNCTIONAL PARTS LIST

(1)				(2)	(3)						(4)	(5)	(6)	(7)	(8)	(9)					
SOURCE MAINTENANCE AND RECOVERABILITY CODE				FEDERAL STOCK NUMBER	DESIGNATION BY MODEL						DESCRIPTION	UNIT OF ISSUE	EXP	QTY INC IN UNIT	ILLUSTRATIONS						
					1	2	3	4	5	6						FIG NO	ITEM NO				
											ITEMS COMPRISING AN OPERABLE EQUIPMENT										
											RADIO TRANSMITTER T-368/URT, T-368A, B, C, D, E/URT										
											NOTE: Model Column 1 refers to T-368/URT; Column 2 refers to T-368A/URT; Column 3 refers to T-368B/URT; Column 4 refers to T-368C/URT; Column 5 refers to T-368D/URT; Column 6 refers to T-368E/URT.										
				5820-503-2640							RADIO TRANSMITTER, T-368/URT; T-368A, B, C, D, E/URT: A1, A2, A3, F1 and F3 emission; 1.5 to 20.0 mc freq range, 5 hands; MD controlled; max pwr output 150 w cw, 675 w AW; 115v, 50-60 cyc single ph; 30-1/2 in lg x 19-1in dp x 41 in h o a						ea.	NX			
				Ord thru AGC	†	†	†	†	†	†	TECHNICAL MANUAL: TM 11-809-10						ea.	X	2		
				5915-500-5967				†			ADAPTER, CONNECTOR: UG-306/U						ea.	X	1		
				5935-201-3091				†			ADAPTER, CONNECTOR: type UG-319A/U, 2 cont, 2 connector, 1.533 in lg x 19 32 in dia; SigC dwg No. SC-D-72331						ea.	X	1		
				5995-164-7692	†	†	†	†	†	†	CABLE, ASSEMBLY, POWER ELECTRICAL: CD-763; 13 ft lg; SigC dwg No. SC-D-27156						ea.	X	1		
				5820-310-2430	†	†	†	†	†	†	CHART, SET CALIBRATION: 16 pgs, 7-3/4 in lg x 6 in w; B and W dwg No. C-13720						ea.	X	1		
				5120-293-1344	†	†	†	†	†		WRENCH, SOCKET HEAD SCREW: hex type 3 6 in across flats; 3 in lg, o a; B and W part; dwg No. V-13578						ea.	NX	1		
				5720-198-5401		†	†	†	†		WRENCH, SOCKET HEAD SCREW: L type handle; 1-56/64 in lg; Allen code No. 050						ea.	NX	1		
				5120-198-5398		†	†	†	†	†	WRENCH, SOCKET HEAD SCREW: L type handle; 1-51/64 in lg; Allen code No. 116						ea.	NX	1		
						†	†	†	†		WRENCH, SOCKET HEAD SCREW: L type handle; 1-61/64 in lg; Allen code No. 564 Ord; Stk No. 41-W-2446						ea.	NX	1		
											RUNNING SPARES AND ACCESSORY ITEMS										
											RADIO TRANSMITTER T-368/URT, T-368A, B, C, D, E URT										
						†	†	†	†	†	Ø ELECTRON TUBE: MIL type OA2						ea.	X	2		V3 V5 V6 V7 V8
						†	†	†	†	†	Ø ELECTRON TUBE: MIL type JAN 3B2B						ea.	X	1		V18 V19
						†	†	†	†	†	Ø ELECTRON TUBE: MIL type 4-400A						ea.	X	1		V1
						†	†	†	†	†	Ø ELECTRON TUBE: MIL type 4D21						ea.	X	1		V9 V10

T-368/URT, T-368A, B, C, D, E/URT

SECTION VI. ALLOCATION OF TOOLS FOR MAINTENANCE FUNCTIONS

TOOLS REQUIRED FOR MAINTENANCE FUNCTIONS	1 ST ECH	2 ND ECH	3 RD ECH	4 TH ECH	5 TH ECH	TOOL CODE	REMARKS
OA-1675/GRC (continued)							
TOOL EQUIPMENT TE-41		†				1	
TOOL EQUIPMENT TE-113			†	†	†	2	

OA-1675/GRC

BY ORDER OF THE SECRETARIES OF THE ARMY AND THE AIR FORCE:

G. H. DECKER,
*General, United States Army,
Chief of Staff.*

OFFICIAL:

R. V. LEE,
*Major General, United States Army,
The Adjutant General.*

CURTIS E. LEMAY,
*General, United States Air Force.
Chief of Staff.*

OFFICIAL:

R. J. PUGH,
*Colonel, United States Air Force,
Director of Administrative Services.*

Distribution :

Active Army:

DASA (6)	USATC Engr (2)	Army Tml (1)
USASA (2)	USATC FA (2)	POE (1)
CNCB (1)	USATC Inf (2)	OSA (1)
Tech Stf, DA (1) except	Svc Colleges (2)	AMS (1)
CSigO (15)	Br Svc Sch (2)	Sig Fld Maint Shops (2)
Tech Stf Bd (1)	GENDEP (2) except	JBUSMC (2)
USCONARC (4)	Atlanta GENDEP (None)	Units org under fol TOE:
USAARTYBD (1)	Sig Sec., GENDEP (5)	(2 each UNOINDC)
USAARMBD (2)	Sig Dep (12)	11-7
USAIB (1)	Ft Monmouth (63)	11-15
USARADB (2)	AFIP (1)	11-16
USAABELCTBD (1)	WRAMC (1)	11-18
USAAVNBD (1)	AFSSC (1)	11-38
USAATBD (1)	USAEPG (2)	11-95
ARADCOM (2)	EMC (1)	11-98
ARADCOM Rgn (2)	USACA (2)	11-117
OS Maj Comd (2)	USASEA (1)	11-155
OS Base Comd (2)	USA Caribbean Sig Agcy (1)	11-500 AA-AE (4)
LOGCOMD (2)	USA Sig Msl Spt Agcy (12)	11-557
MDW (1)	USASSA (20)	11-587
Armies (2)	USSASSAMOR (1)	11-592
Corps (5)	Army Pictorial Cen (2)	11-597
USATC AD (2)	USAOMC (3)	39-61
USATC Armo f (2)	USA Trans Tml Comd (1)	

NG: State AC (3)

USAR: None.

For explanation of abbreviations used, see AR 320 - 50.

Operators Manual

**RADIO TRANSMITTERS T-368/URT, T-368A/URT, T-368B/URT, T-368C/URT,
T-368D/URT, AND T-368E/URT; ANTENNA TUNING UNIT BC-939-B; RADIO
FREQUENCY TUNER TN-3391GR; AND STANDING WAVE RATIO-POWER METER ME-
165/G**

CHANGE }
NO. 4 }

HEADQUARTERS
DEPARTMENT OF THE ARMY
WASHINGTON, DC, 10 October 1968

TM 11-809-10, 14 May 1958, is changed as follows:

Note. The parenthetical reference to previous changes (example: "page 1 of C 3") indicates that pertinent material was published in that change.

The following symbol is applicable to this manual:

RADIATION HAZARD

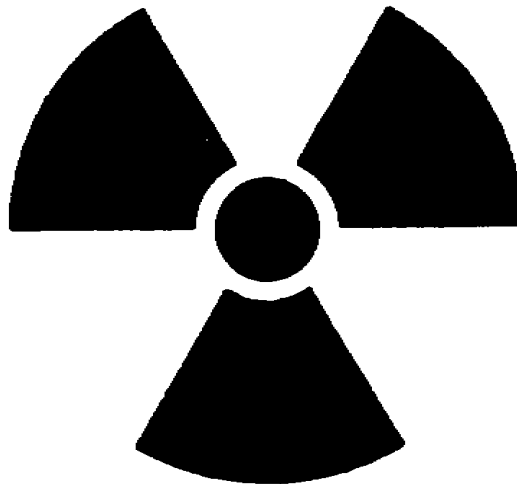

STD-RW-2

**Ni 63
Co 60
Ra 226
Cs 137
C 14**

Tube types OA2 used in the transmitter contain radioactive material. These tubes are potentially hazardous when broken; see qualified medical personnel and the Safety Director if you are exposed to, or cut by, broken tubes.

Use extreme care in replacing these tubes and follow safety procedures in their storage and disposal (par. 28.1).

Never place a radioactive tube in your pocket.

Use extreme care not to break radioactive tubes while handling them.

Never remove radioactive tubes from cartons until ready to use them
Refer to paragraph 28.1 on handling, storage, and disposal of radioactive material.

Page 3. Add paragraph 1.1 after paragraph 1.

1.1. Index of Publications

Refer to the latest DA Pam 310-4 to determine whether there are new editions, changes, or additional publications pertaining to the equipment. Department of the Army Pamphlet No. 310-4 is an index of current technical manuals, technical bulletins, supply bulletins, lubrication orders, and modification work orders available through publications supply channels. The index lists the individual parts (-0, -20, -35P, etc.) and the latest changes to and revisions of each equipment publication.

Delete paragraph 2 (page 1 of C3) and substitute:

2. Forms and Records

a. Reports of Maintenance and Unsatisfactory Equipment. Use equipment forms and records in accordance with instructions in TM 38-750.

b. Report of Damaged or Improper Shipment. Fill out and forward DD Form 6 (Report of Damaged or Improper Shipment) as prescribed in AR 700-58 (Army), NAVSANDA Publication 378 (Navy), and AFR 71-4 (Air Force).

c. Reporting of Equipment Manual Improvements. The direct reporting by the individual user of errors, omissions, and recommendations for improving this manual is authorized and encouraged. DA Form 2028 (Recommended Changes to DA Technical Manual Parts Lists or Supply Manual 7, 8 or 9) will be used for reporting these improvements. This form will be completed in triplicate using pencil, pen, or typewriter. The original and one copy will be forwarded direct to: Commanding Officer, U.S. Army Electronics Materiel Support Agency, ATTN: SELMS-MP, Fort Monmouth, N. J.,

07703. One information copy will be furnished to the individual's immediate supervisor (officer, noncommissioned officer, supervisor, etc.).

Page 33. Delete paragraphs 26 and 26 and substitute:

25. Scope of Maintenance

The maintenance duties assigned to the operator of the equipment are listed below together with a reference to the paragraphs covering the specific maintenance functions. These procedures do not require tools or test equipment.

- a.* Daily preventive maintenance checks and services (par. 26.2).
- b.* Weekly preventive maintenance checks and services (par. 26.3).
- c.* Cleaning (par. 26.4).
- d.* Replacement of fuse (figs. 3 and 6).

26. Preventive Maintenance

Preventive maintenance is the systematic care, servicing, and inspection of equipment to prevent the occurrence of trouble, to reduce downtime, and to assure that the equipment is serviceable.

a. Systematic Care. The procedures given in paragraphs 26.1 through 27 cover routine systematic care and cleaning essential to proper upkeep and operation of the equipment.

b. Preventive Maintenance Checks and Services. The preventive maintenance checks and services charts (paras. 26.2 and 26.3) outline functions to be performed at specific intervals. These checks and services are to maintain Army electronic equipment in a combat-serviceable condition; that is, in good general (physical) condition and in good operating condition. To assist operators in maintaining combat serviceability, the charts indicate what to check, how to check, and what the normal conditions are; the *references* column lists the illustrations, paragraphs, or manuals that contain supplementary information. If the defect cannot be remedied by the operator, higher echelon maintenance or repair is required. Records and reports of these checks and services must be made in accordance with the requirements set forth in TM 38-750.

Add paragraphs 26.1 through 26.4 after paragraph 26.

26.1. Preventive Maintenance Checks and Services Periods

Preventive maintenance checks and services of the equipment are required daily and weekly. Paragraph 26.2 specifies the checks and services that must be accomplished daily and under the conditions listed below.

- a. When the equipment is initially installed.

- b. When the equipment is reinstalled after removal for any reason.

- c. At least once each week if the equipment is maintained in standby condition.

- d. Paragraph 26.3 specifies *additional* checks and services that must be performed each week.

26.2. Daily Preventive Maintenance Checks and Services Chart

Sequence No.	Item	Procedure	References
1	Transmitter, tuning unit, an standing wave ratio power meter.	Inspect equipment for completeness (fig. 3).	Par. 6 and appx II.
2	Exterior surfaces	Clean exterior surfaces, including panel and meter glass.	Par. 26.4.
3	Connector	Check all meter glass and indicator lenses for cracks. Check tightness of all external connectors (figs. 1, 4 5, and 6).	
4	Controls and indicators	While making operating checks (item 5), observe that mechanical action of each knob, dial, and switch is smooth and free of external or internal binding, and that there is no excessive looseness. Check meters for sticking or bent pointers (fig. 1).	
5	Operation.....	Operate equipment according to paragraphs 17 through 24. During operation be alert for any unusual signs or conditions.	

26.3 Weekly Preventive Maintenance Checks and Services Chart

Sequence No.	Item	Procedure	References
1	Cables.....	Inspect cords, cables, and wires for chafed, cracked, or frayed insulation. Replace connectors that are broken, arced, stripped, or worn excessively.	Par. 26.4.
2	Handles and latches	Inspect handles, latches, and hinges for looseness Replace or tighten as necessary.	
3	Metal surfaces.....	Inspect exposed metal surfaces for mat and corrosion. Clean as required	

26.4 Cleaning

Inspect the exterior of the equipment. The exterior surfaces should be clean, and free of dust, dirt, grease, and fungus.

- a. Remove dust and loose dirt with a clean soft cloth.

Warning: Cleaning compound is flammable and its fumes are toxic. Provide adequate ventilation. Do not use near a flame.

- b. Remove grease, fungus, and ground-in dirt from the cases; use a cloth dampened (not wet) with Cleaning Compound, FSN 7930-395-9542.

- c. Remove dust or dirt from plugs and jacks with a brush.

Caution: Do not press on the meter face (glass) when cleaning; the meter may become damaged.

- d. Clean the front panels, meters, and control knobs; use a soft clean cloth. If dirt is difficult to remove, dampen the cloth with water; mild soap may be used for more effective cleaning.

Page 34. Delete figure 19.
Page 35. Delete figure 20.
Page 36. Add paragraph 28.1 after paragraph 28.

28.1. Handling, Storage, and Disposal of Radioactive Material

Follow the procedures for safe handling, storage, and disposal of radioactive materials as directed by TB SIG 225, AR 40-580, and AR 755-380.

Page 38, appendix I (page 5 of C 3). Add the following references after the last reference.

AR 40-580	Medical Service: Control of Hazards to Health from Radioactive Materials.
AR 755-380	Disposal of Supplies and Equipment: Disposal of Unwanted Radioactive Material.
DA Pam 310-4	Index of Technical Manuals, Technical Bulletins, Supply Bulletins, Lubrication Orders, and Modification Work Orders.
TB SIG 225	Radioactive Electron Tube Handling
TM 38-750	The Army Equipment Record System and Procedures

BY ORDER OF THE SECRETARY OF THE ARMY:

EARLE G. WHEELER,
*General, United States Army,
Chief of Staff.*

Official:

J. C. LAMBERT,
*Major General, United States Army,
The Adjutant General.*

Distribution:

Active Army,

DASA (6)	Lexington (12)
USASA (2)	Sacramento (28)
CNGB (1)	Tobyhanna (12)
Cof Engrs (1)	USA Elct RD Actv, White Sands (13)
TSG (1)	USA Elct RD Actv, Ft Huachuca (2)
CSigO (7)	USA Trans Tml Comd (1)
CofT (1)	Army Tml (1)
CofSptS (1)	POE (1)
USA CD Agcy (1)	USAOSA (1)
USCONARC (6)	AMS (1)
USAMC (6)	WRAMC (1)
ARADCOM (2)	AFIP (1)
ARADCOM Rgn (2)	Army Pic Cen (2)
OS Maj Comd (3)	USA Mbl Spt Cen (1)
OS Base Comd (2)	USA Elct Mat Agcy (12)
LOGCOMD (2)	Chicago Proc Dist (1)
USAECOM (6)	USARCARIB Sig Agcy (1)
USAMICOM (4)	Sig Fld Maint Shop (3)
USASCC (4)	Units organized under following TOE
MDW (1)	(2 cy ea UNOINDC)
Armies (2)	11-7
Corps (2)	11-16
USA Corps (8)	11-57
USATC AD (2)	11-97
USATC Engr (2)	11-98
USATC Inf (2)	11-117
USATC Armor (2)	11-155
USASTC (5)	11-157
Instl (2) except	11-500 (Tms AA-AC) (4)
Ft Monmouth (65)	11-557
Svc Colleges (2)	11-587
Br Svc Sch (2) except	11-592
USASCS (65)	11-597
GENDEP (OS) (2)	20-45
Sig Dep (OS) (12)	20-46
Sig Sec, GENDEP (5)	82-56
Army Dep (2) except	32-67
Ft Worth (8)	

NG: State AG (3); units -- same as active Army except allowance is one copy to each unit.

USAR: None.

For explanation of abbreviations used, see AR 320-50.

TAGO 6420A

Change }
No. 5 }

HEADQUARTERS
DEPARTMENT OF THE ARMY
Washington, D.C., 19 October 1973

**Operator's Manual
RADIO TRANSMITTERS T-368/URT, T-368A/URT
T-368B/URT, T-368C/URT, T-368D/URT
AND T-368E/URT; ANTENNA TUNING UNIT
BC-939-B; AND RADIO FREQUENCY TUNER TN-339/GR**

TM 11-809-10, 14 May 1958, is changed as follows:
The title is changed as shown above.

Page 3, paragraph 1.1 Delete paragraph 1.1 and substitute new paragraph 1.1.

1.1. Indexes of Publications

a. *DA Pam 310-4.* Refer to the latest issue of DA Pam 310-4 to determine whether there are new editions, changes, or additional publications pertaining to the equipment.

b. *DA Pam 310-7.* Refer to DA Pam 310-7 to determine whether there are modification work orders (MWO's) pertaining to the equipment.

Paragraph 2. Delete paragraph 2 and substitute new paragraph 2.

2. Forms and Records

a. *Reports of Maintenance and Unsatisfactory Equipment.* Maintenance forms, records, and reports which are to be used by maintenance personnel at all maintenance levels are listed in and prescribed by TM 38-750.

b. *Report of Packaging and Handling Deficiencies.* Fill out and forward DD Form 6. (Report of Packaging

and Handling Deficiencies) as prescribed in AR 700-58 (Army)/NAVSUP Pub 378 (Navy)/AFR 71-4 (Air Force)/and MCO P4030.29 (Marine Corps).

c. *Discrepancy in Shipment Report (DISREP) (SF 361).* Fill out and forward Discrepancy in Shipment Report (DISREP) (SF 361) as prescribed in AR 55-38 (Army)/NAVSUP Pub 459 (Navy)/AFM 75-34 (Air Force)/and MCO P4610.19 (Marine Corps).

Add paragraph 2.1 after paragraph 2.

2.1. Reporting of Equipment Publication Improvements

The reporting of errors, omissions, and recommendations for improving this publication by the individual user is encouraged. Reports should be submitted on DA Form 2028 (Recommended Changes to Publications) and forwarded direct to Commander, US Army Electronics Command, ATTN: AMSEL-MA-C, Fort Monmouth, NJ 07703.

Page 4, paragraph 6. Change title to "Components and Dimensions of Radio Transmitter T-368(*)/URT." After paragraph 6 add paragraph 6.1.

6.1. Items Comprising an Operable Radio Transmitter T 368(*)/URT (FSN 5820-503-2640)

FSN	QTY	Nomenclature, part No and mfr code	Fig. No.
		NOTE In usable on code column number 1 refers to T-368/URT; number 2 refers to T-368A/URT; number 3 refers to T-368B/URT; number 4 refers to T 368C/URT; number 5 refers to T-368D/URT; number 6 refers to T-368E/URT	
		NOTE The part number is followed by the applicable 5-digit Federal supply code for manufacturers (FSCM) identified in SB 708-42 and used to identify manufacturer, distributor, or Government agency, etc.	
5915-500-5967	1	Adapter, Connector UG-306U	3
5935-201-3091	1	Adapter, Connector type UG-349A/U, 2 cont., 2 connector, 1.533 in. lg x 19 32 in. dia; SC-D-72331; 80063	3
5995-164-7692	1	Cable, Assembly, Power Electrical: CD-763; 13 ft lg. SC-D-27156; 80063	1, 2, 3, 4, 5, 6
5820-310-2430	1	Chart, Set Calibration; 16 pgs 7-3 4 in. lg. x 6 in. w; B and W dwg No. C-13720	1, 2, 3, 4, 5, 6
6625-510-1841	1	Prod Test shorting stick; SC-DL-27351; 80063	1, 2, 3, 4, 5, 6

Page 38, appendix II. Delete appendix II and substitute new appendix II.

APPENDIX II ITEMS TROOP INSTALLED OR AUTHORIZED LIST

Section 1. INTRODUCTION

1. Scope

This appendix lists only items troop installed or authorized required by the crew/operator for installation, operation, and maintenance of Radio Transmitters T-368/URT, T-368A/URT, T-368B URT, T-368C/URT, T-368D/URT, and T-368E/ URT; Antenna Tuning Unit BC-939-B; Radio Frequency Tuner TN-339/GR; and Standing Wave Ratio-Power Meter ME-165/G.

2. General

Items Troop Installed or Authorized List-Section II. A list, in alphabetical sequence, of items which, at the discretion of the unit commander, may accompany the end item, but are not subject to be turned in with the end item.

3. Explanation of Columns.

The following provides an explanation of columns found in the tabular listings:

- a. *Illustrations.* Not applicable.
- b. *Federal Stock Number.* Indicates the Federal stock number assigned to the item and will be used for requisitioning purposes.
- c. *Part Number.* Indicates the primary number used by the manufacturer (individual, company, firm, corporation, or government activity), which controls the design and characteristics of the item by means of its engineering drawings, specifications standards, and inspection requirements, to identify an item or range of items.
- d. *Federal Supply Code for Manufacturer*

(FSCM) The FSCM is a 5-digit numeric coda used to identify the manufacturer, distributor, or Government agency, etc., and is identified in SB 708-42

e. Description Indicates the Federal item name and a minimum description required to identify the item.

f. Unit of Measure (U/M). Indicates the standard of basic quantity of the listed item as used in performing the actual maintenance function. This measure is expressed by a two-character alphabetical abbreviation, (e.g., ea. in., pr, etc). When the unit of measure differs from the unit of issue, the lowest unit of issue that will satisfy the required units of measure will be requisitioned.

g. Quantity Furnished with Equipment. Not applicable.

h. Quantity Authorized (Items Troop Installed or Authorized Only). See Section II.

4. Special Information

Usable on codes are included in Column 4. Uncoded items are applicable to all models. Identification of the usable on codes are as follows:

Code	Used on
1	T-368/URT
2	T-368A/URT
3	T-368B/URT
4	T-368C/URT
5	T-368D/URT
6	T-368E/URT

Section II. ITEMS TROOP INSTALLED OR AUTHORIZED LIST

(1) Federal Stock Number	(2) Part number	(3) FSCM	(4) Description	(5) Usable on code	(6) Unit of meas	(6) Qty auth
5120-293-1344	B-13578		WRENCH, SOCKETHEAD SCREW: hex type 3/8 in. across flats; 3 in. 4, o/a; BandW	1, 8, 3, 4, 5	EA	1
5720-198-5401	050	08929	WRENCH, SOCKETHEAD SCREW: L type handle 1-56/64 in. lg	2, 3, 4, 5	EA	1
5120-198-5398	116	08929	WRENCH, SOCKETHEAD SCREW: L type handle; 1-51 64 in. lg		EA	1
	564	08929	WRENCH, SOCKETHEAD SCREW: L type handle; 1-61/64 in. lg. Ord Stk No. 41-W-2446		EA	1

By Order of the Secretary of the Army:

CREIGHTON W. ABRAMS
General, United States Army
Chief of Staff

Official:

VERNE L. BOWERS
Major General, United States Army
The Adjutant General

Distribution:

To be distributed in accordance with DA Form 12-51, Operator maintenance requirements for BC-939, T-368/URT and TN 339/GR.



WASHINGTON 25, D.C., 14 May 1958

**RADIO TRANSMITTERS T-368/URT, T-368A/URT, T-368B/URT, AND
 T-368C/URT, AND ANTENNA TUNING UNIT BC-939-B**

			Paragraph	Page
CHAPTER	1.	INTRODUCTION		
Section	I.	General		
		Scope.....	1	3
		Forms and records	2	3
	II.	Description and data		
		Purpose and use	3	3
		Application	4	4
		Technical characteristics	5	4
		Components of Radio Transmitter T-368(*)/URT	6	4
		Description of transmitter	7	5
		Description of antenna tuning unit	8	7
		Additional equipment required.....	9	7
		Differences in models	10	8
CHAPTER	2.	OPERATING INSTRUCTIONS		
Section	I.	Controls and instruments		
		General.....	11	10
		Transmitter	12	10
		Antenna tuning unit	13	11
	II.	Operation		
		Checking connections	14	15
		Tuning charts	15	15
		Preliminary starting procedure	16	28
		Tuning procedure.....	17	28
		Starting procedure	18	31
		Cw operation	19	31
		AM operation	20	31
		EXT EXC operation	21	32
		FSK operation.....	22	32
		FSK-AM operation	23	32
		Stopping procedure.....	24	32
CHAPTER	3.	MAINTENANCE INSTRUCTIONS		
		Scope of operator's maintenance	25	33
		Preventive maintenance	26	33
		Visual inspection	27	33
		Operational checklist	28	33
	4.	SHIPMENT AND LIMITED STORAGE AND DEMOLITION TO PREVENT ENEMY USE		
Section	I.	Shipment and limited storage		
		Disassembly.....	29	37
		Repackaging for shipment or limited storage	30	37
	II.	Demolition of materiel to prevent enemy use		
		Authority for demolition	31	37
		Methods of destruction.....	32	37
APPENDIX		REFERENCES		38

* This manual supersedes so much of TM 11-809/TO 31R2-2URT-101, 22 April 1955, including C 1, 11 December 1956; C 2, 24 January 1957; C 3, 4 April 1957; and C 4, 8 May 1957, as pertains to operations.
 AGO 5429A—April

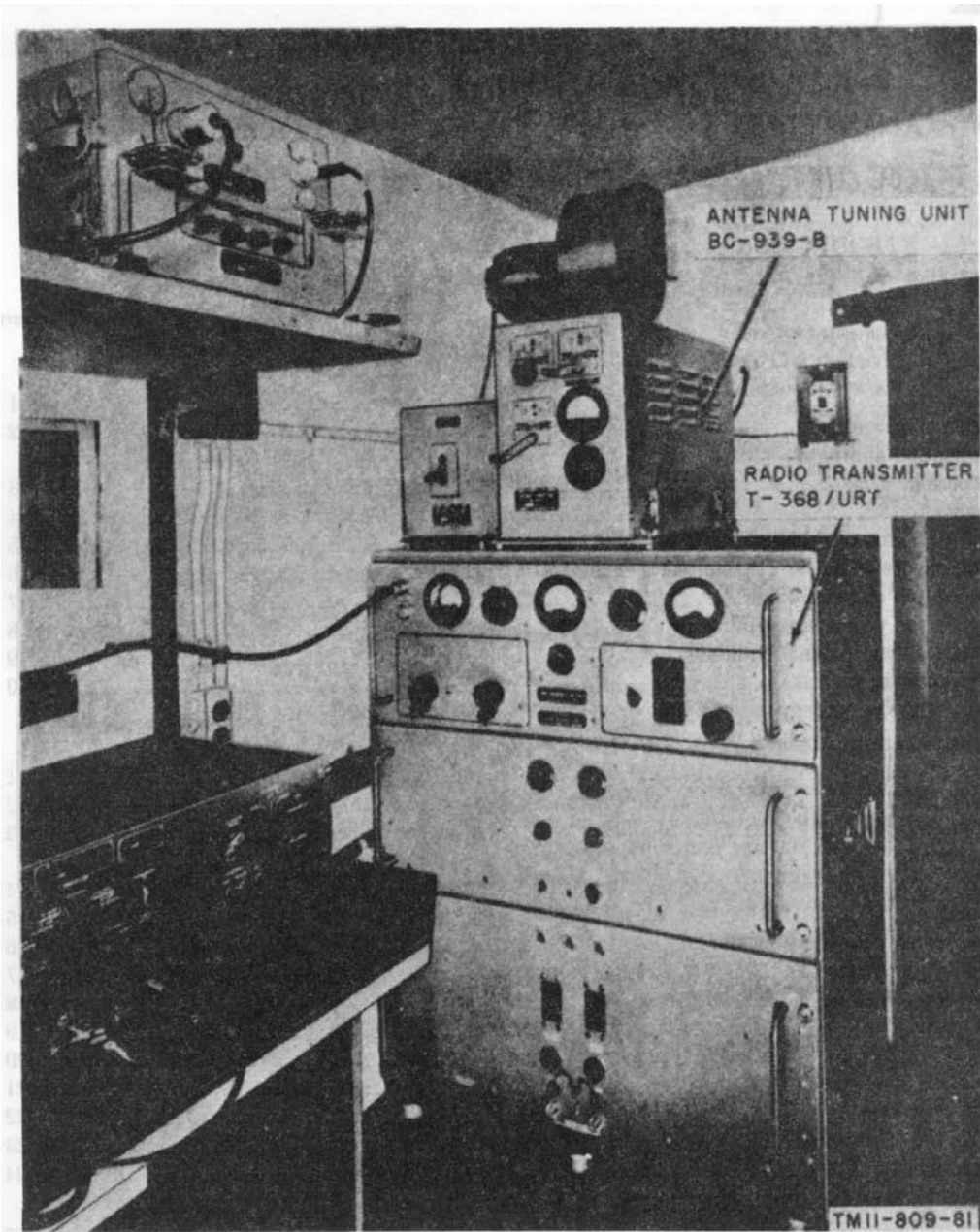

Figure 1. Radio Transmitter T-368/URT and Antenna Tuning Unit BC-939-B.

CHAPTER 1

INTRODUCTION

Section I. GENERAL

1. Scope

a. General. This manual covers operation and operator's maintenance of Radio Transmitter T-368 (*)/URT and Antenna Tuning BC-939-B (fig. 1). Throughout this manual, Radio Transmitter T-368 (*)/URT is called the transmitter, and Antenna Tuning Unit BC-939-B is called the tuning unit. Appendix I is a list of references applicable to this equipment.

b. Maintenance Allocations Charts. Maintenance Allocations Charts for the transmitter and the tuning unit will be included in TM 11-809-20.

c. Repair Parts and Special Tool Lists. Refer to DA Supply Manual SIG 7 & 8 AN/ GLQ-2 for maintenance parts information for the transmitter; and to SIG 7 & 8 BC-939 for maintenance parts information for the antenna tuning unit.

d. Models. Official nomenclature followed by (*) is used to indicate all models of the transmitter covered in this manual. Thus, Radio Transmitter T-368 (*)/URT represents Radio Transmitters T-368/URT, T-368A/URT, T-368B/URT, and T-368C/URT.

e. Comments. Forward comments on this publication direct to Commanding Officer, United States Army Signal Publications Agency, Fort Monmouth, New Jersey.

2. Forms and Records

a. Unsatisfactory Equipment Reports.

- (1) Fill out and forward DA Form 468 (Unsatisfactory Equipment Report) to Commanding Officer, United States Army Signal Equipment Support Agency, Fort Monmouth, New Jersey, as prescribed in AR 700-38.
- (2) Fill out and forward AFTO Form 29, Unsatisfactory Report, to Commander, Air Materiel Command, Wright-Patterson Air Force Base, Ohio, as prescribed in AF TO 00-35D-54.

b. Damaged or Improper Shipment. Fill out and forward DD Form 6, Report of Damaged or Improper Shipment, as prescribed in AR 700-58 (Army) and AFR 71-4 (Air Force).

c. Preventive Maintenance Form. Prepare DA Form 11-238, Maintenance Check List for Signal Equipment (Sound Equipment, Radio, Direction Finding Radar, Carrier, Radiosonde and Television) (figs. 19 and 20) in accordance with instructions on the form.

Section II. DESCRIPTION AND DATA

3. Purpose and Use

a. The transmitter is a medium power radio communications transmitter which transmits continuous wave (cw) and amplitude modulated (AM) signals over a distance of more than 100 miles. The frequency range of the transmitter is from 1.5 to 20 megacycles (mc). The transmitter radio-frequency (rf) output power is 400 to 460 watts with input power of 1,570 to 2,200 watts from a 116-volt, 50- to 60-cycle alternating-current (ac) source.

b. The transmitter is also used as a power amplifier

for low-powered exciter units or as a driver for high-powered transmitters. When used as an amplifier, the transmitter is capable of transmitting frequency-shift keying (FSK) signals and other types of signals, such as narrow-band frequency-modulated signals. FSK and am operations can also be combined for simultaneous transmission on one carrier frequency.

c. Antenna Tuning Unit B-939-B must be used with the transmitter when a long-wire or whip antenna is used. The tuning unit covers a frequency range of 2 to 20 (mc).

4. Application

(fig. 2)

The transmitter is limited to cw and AM operation when used as a single unit. For other types of modulation the transmitter amplifies modulated rf signals from an external exciter. The system application of Radio Transmitter T-368 (*)/URT is described in a through g below

a. For cw operation, a hand key is used to interrupt the rf carrier. A headset or a loudspeaker can be used to listen to a side-tone signal keyed simultaneously with the rf carrier. This enables monitoring the operator's keying.

b. In AM operation, a carbon microphone is used to modulate the transmitter carrier in accordance with voice variations. The carrier may also be modulated by using a telephone set over a 600-ohm line.

c. For FSK and FSK-AM operations, a frequency-shift exciter feeds keyed signals into the transmitter, the signals are then amplified and transmitted. A teletypewriter is the keying source.

d. For EXT EXC operation, narrow-band frequency-modulated signals (or equivalent) are fed into the transmitter and are then amplified and transmitted.

e. When any transmitter except the T-368/URT (basic model) is used in Radio Set AN/GRC-26D, the FSK and EXT EXC receptacles are connected to an FSK modulator. Internal connections of the transmitter are recabled and the transmitter then functions as a signal source for the FSK modulator. The FSK modulator, in turn, keys the transmitter in accordance with teletypewriter signals for FSK operation

f. For remote control operation, a receptacle on the rear of the transmitter permits cabling to a remote control box. A relay in the control box will disable a receiver when the transmitter is in operation.

g. The transmitter may be used in fixed station or mobile operation. A doublet or long-wire antenna is used for fixed station operation, and a whip antenna is used for mobile operation. Antenna Tuning Unit BC-939-B matches the impedance of a long-wire or whip-type antenna to the transmitter.

5. Technical Characteristics

Frequency range	1.5 to 20.0 mc.
Distance range	Over 100 miles.
Transmitter type	Master oscillator, frequency multiplier, intermediate power amplifier, and power amplifier.
Types of signals transmitted.....	Cw and AM.
Type of modulation.....	Amplitude.
Input signal levels:	
FSK.....	3 to 5 volts.
External excitation.....	30 volts (max)
Input impedance:	
FSK.....	56 ohms.
External excitation.....	1,000 ohms.
Number of tubes.....	25 in basic model, 29 in all other models.
Antennas:	
Fixed station operation.....	Doublet of proper length to match operating frequency. Long-wire with antenna tuning unit.
Mobile operation.....	Whip-type with antenna tuning unit.
Power output:	
Cw.....	450 watts (approx.).
AM.....	400 watts (approx.).
Power input.....	115 volts, 50-60 cps, 1 phase; 1,570 watts (cw) or 2,200 Watts (AM); power factor .91 (cw) or .994 (AM).
Weight	650 pounds.

6. Components of Radio Transmitter T-368(*)/URT

a. *Components.* The transmitter components (fig. 3) are listed in the following chart:

Component	Required No.	Overall			Volume (Cu. Ft.)	Unit weight (lb.)
		Height (in.)	Depth (in.)	Width (in.)		
Transmitter	1	41 1/2	31	32	24	650
Cord CD-763	1	13 ft (lg)	5
Jumper plug (installed)	1	2 1/2 (lg)	1 1/2 (dia)
Manuals	2	10 1/4	7 7/8
Running spares (<i>b</i> below).....	1 set
Total weight (lb).....	655

AGO 5429A

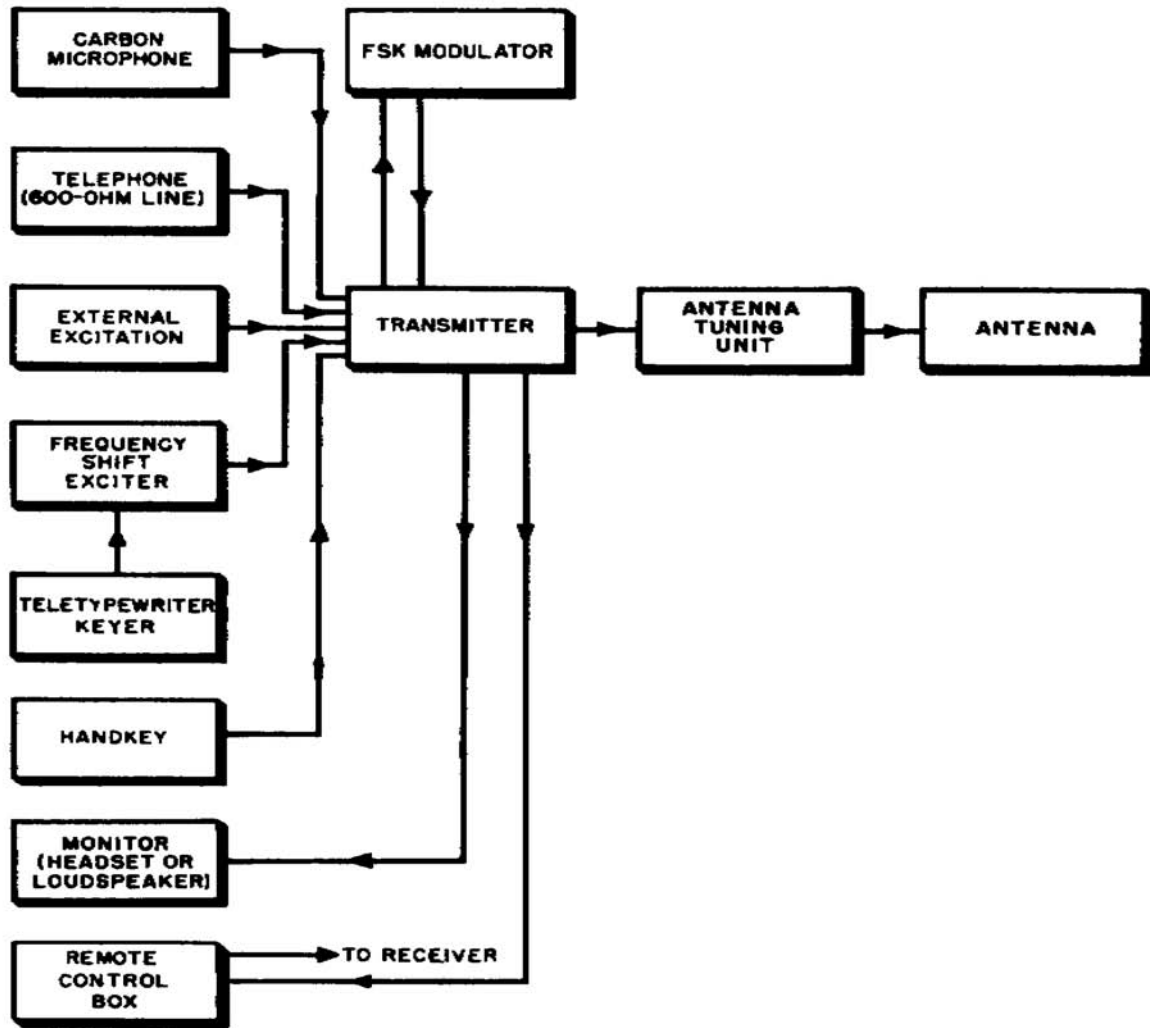

TM809-10-3

Figure 2. System application, block diagram.

b. Running Spares.

Basic model	Lettered models
2 tubes, OA2.....	2 tubes, OA2
1 tube, 3B28	1 tube, 3B28
1 tube, 4D21	1 tube, 4D21
1 tube, 4-400A	1 tube, 4-400A
1 tube, 5R4WGY	2 tubes, 5R4WGA
1 tube, 6C4W.....	1 tube, 6C4W
1 tube, 6AH6	1 tube, 6AH6
1 tube, 6000.....	1 tube, 6000
1 tube, 5749/6BA6W	1 tube, 5749/6BA6W
1 tube, 12AT7.....	1 tube, 12AT7WA
1 tube, 5726/6AL5W.....	1 tube, 5726/6AL5W
1 tube, 5814.....	1 tube, 5814WA
1 tube, 5933/807W.....	1 tube, 5933
1 incandescent lamp, 6 watts, 110 to 120 volts	1 incandescent lamp, 6 watts, 110 to 120 volts
6 cartridge fuses, 3 amperes, 250 volts	3 cartridge fuses, 3 amperes, 250 volts

6 cartridge fuses, 6 amperes, 250 volts

3 cartridge fuses, 6 amperes 250 volts

7. Description of Transmitter

(figs. 3, 4, and 5)

a. The equipment consists of three separate decks contained in a cabinet rack. The decks, from top to bottom, are the rf, the modulator, and the power supply. Captive bolts and handles on each deck permit unfastening and removal of the decks from the housing for servicing and adjustment purposes.

b. The rf deck (fig. 3) contains all the rf controls and the meters of the equipment on its front panel. Each tuning control contains its own mechanical counter. Two coaxial receptacles, FSK and EXT EXC (fig. 6), provide a means of bringing in outside signals for increasing the types of service selected by the SELECTOR SERVICE switch. The exciter stages are mounted on subassemblies and can be removed easily for servicing and adjusting.

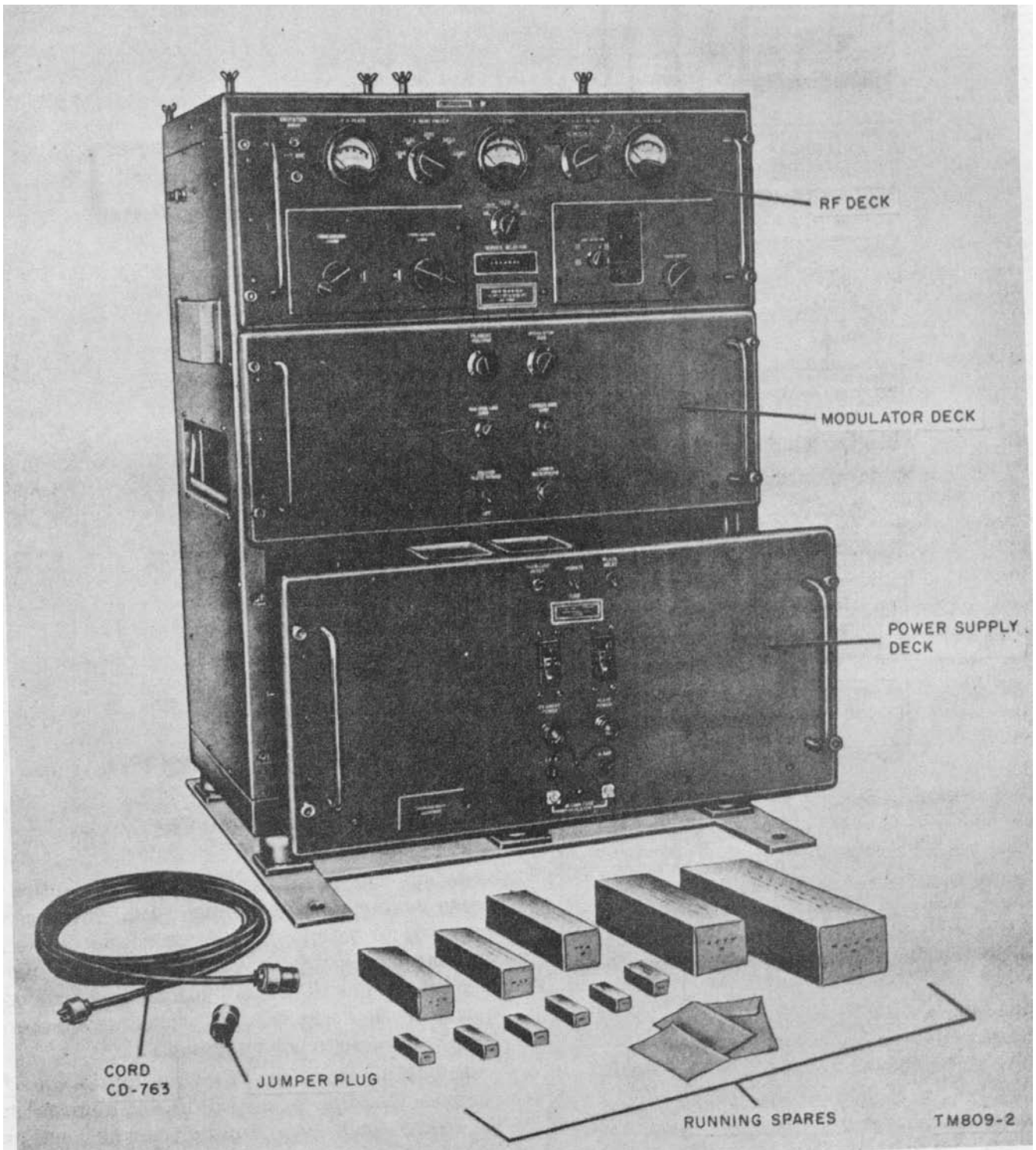

Figure 3. Radio Transmitter T-368/URT, components.

c. The modulator deck (fig. 3) contains all the modulation controls of the equipment. The chassis contains a speech amplifier subassembly which can be easily removed for testing purposes. A receptacle is provided to connect either a handkey or a microphone to the transmitter.

d. The power supply deck (fig. 3) contains the protection and indicator devices and all of the ac controls except the THERMAL RESET switch of the equipment. A small plate covers the two controls used to adjust the overload relay. The panel lamps, fuses, and blown fuse indicators are located on the front panel.

e. The cabinet contains all the interlock switches of the equipment. Three receptacles are located on the rear of the cabinet (fig. 4). The power receptacle permits the application of ac power, the second receptacle seats the jumper plug to permit high-voltage operation, and the third provides means for remote control operation. Two coaxial receptacles (fig. 6) on the left side of the cabinet connect the transmitting antenna to the transmitter and to a receiver (when used) through an antenna change-over relay. A blower, located on the teach panel, improves the ventilation of the equipment; air filters (fig. 4) clean the incoming air. A holder (fig. 5), mounted on the left side, stores the calibration charts used with the transmitter. In Radio Transmitters T-368A/URT and T-368C/URT, the holder is mounted on the right side of the cabinet. Carrying handles for the transmitter (one on each side) when not in use, can be folded into the sides of the housing. A hexagonal T-socket wrench (fig. 4), used for loosening and tightening the panel captive bolts, is mounted in the recess for the right side handle. At the top of the cabinet are two sets of four threaded studs with wing nuts for mounting a switching unit (in Radio Set AN/GLQ-2 2) or Radio Modulator M239/GR (in Radio Set AN/GRD-26D) and an antenna tuning unit (fig. 1). A THERMAL RESET button (fig. 6) on the top of the upper front section of the cabinet permits manual re-setting of the thermostat, which is mounted on the inside top of the cabinet. Radio Transmitters T-368/URT and T-368B/URT have sex shock mounts (fig. 4) which attach to a flat rectangular plate. On the other transmitters eight shock mounts

attach to a U-channel rectangular base; the base is secured to the mounting surface by four bolts (not supplied). The rear aprons of the deck chassis can be reached by loosening the Dzus screws that hold the back panel to the cabinet.

8. Description of Antenna Tuning Unit (fig. 1)

All controls and the meter are mounted on the front panel. Terminals on the side and rear connect the unit to the transmitter and to an antenna. Four spring clasps are mounted on the cover to fasten it to the body. The entire unit is mounted on top of the transmitter and is secured by four wing nuts. The unit weighs 48 pounds.

9. Additional Equipment Required

The additional equipment required for the operation of the transmitter depends on the type of service to be performed. In all types of installations, it is necessary to have a power source of 116 volts ac, 2,200 watts minimum; a frequency calibrating device; and an antenna system. The following basic equipment IS required for the five types of operation of the transmitter:

a. Cw operation requires a handkey such as Key KY-116/U with Special Purpose Cable Assembly CX-1862/U or equivalent.

b. AM operation requires a handkey such as phone such as Microphone M-29A/U with its cable or its equivalent. For remote control operation, a telephone set that works through a 600-ohm line is connected to remote control receptacle J12.

c. FSK operation of Radio Transmitter T-368/URT requires the use of an exciter unit such as Frequency Shift Exciter O-39/TRA-7, O-39A/TRA-7, O-39B/TRA-7, or O-39C/TRA-7, or its equivalent and a teletypewriter such as Teletypewriter TT 4A/TG or its equivalent. Radio Transmitters T-368A/URT, T-368B/URT, and T-368C/URT are designed for FSK operation in conjunction with Radio Modulator md-239/GR, or its equivalent, and a teletypewriter.

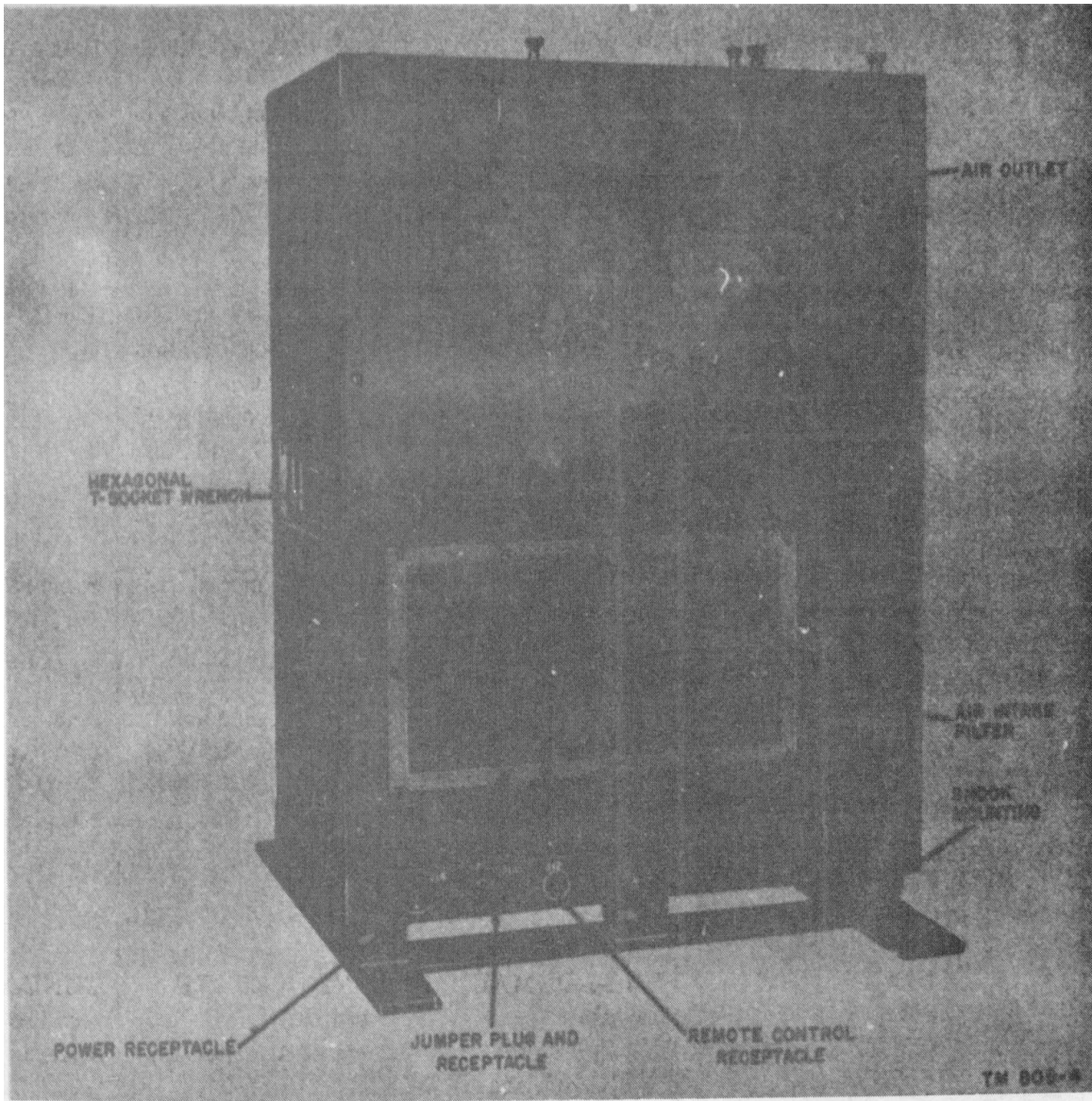

Figure 4. Transmitter, rear view.

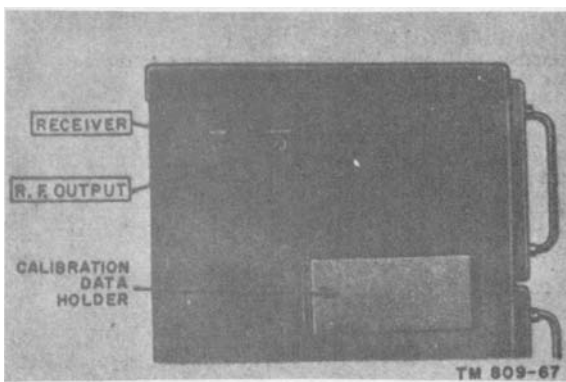

Figure 5. Transmitter housing, left side.

d. FSK-AM operation combines the units used in both AM and FSK operation.

e. EXT EXC operation requires any unit capable of generating rf signals in the 1.5 to 6.0 (mc). range. The transmitter will accept narrow-band frequency-modulated signals also.

10. Differences in Models

Radio Transmitters T-368/URT, T-368A/URT, T-368B/URT, and T-368C/URT are similar in purpose, operation, and appearance. The model differences are listed in the following chart:

Item	Basic model	A model	B model	C model
High-voltage plate transformer T9.	Dual primary	Dual primary	Single untapped primary.	Single untapped primary
Antenna change-over relay system.	5,760-volt, 475-ma secondary. Dual relay K1A and KB used.	6,350-volt, 500-ma secondary. K1 replaces K1B.....	6,160-volt, 500-ma secondary. K11 replaces K1B.....	6,336-volt, 0 500-ma secondary. Same as B; model (reference symbols of B and C model components are identical)
Circuit to protect intermediate amplifier tube V104 in the event of loss of excitation.	Not present	Slow release section K1A replaced by a circuit consisting of tubes V20 and V21, slow release relay K9, and associated components. Uses relay and vacuum tube circuit including V23 and K10.	Slow release section K1A replaced by a circuit consisting of tubes V21 and V22, slow release relay K9, and associated components. Same as A model	Same as A model.
FSK connector	Type UG-58/U.....	Type UG-910/U.....	Same as A model	Same as A model.
Exciter power supply tubes.	V4, 5R4WGY	V4 and V22, 5R4WGA	V4 and V20,5R4WGA	Same as B model.
Exciter plate transformer T3 secondary current rating.	250 ma.....	300 ma.....	300 ma.....	300 ma.
T4 secondary 9-11 current rating.	3-ampere.....	6-ampere.....	4-ampere.....	4-ampere.
Switch S12.....	TUNE-OPERATE switch.	TUNE-NORMAL Switch.	TUNE-OPERATE switch.	TUNE-NORMAL switch
Switch S6.....	EXCITER PLATE POWER switch up(on) and OFF positions.	KEYING switch, NORMAL and CONTINUOUS positions.	Same as A model	Same as A model
Exciter power supply.....	Turned on by EXCITER PLATE POWER switch or plate relay K6.	Energized when FILA-MENT POWER switch b set to ON position.	Same as A model	Same as A model
Blower B2.....	Associated C36 is 2.75 uf.	Same as basic model	Blower B2 increased in size and requires different mounting facilities. Associated C36 is 4 uf.	Same as basic model
Keying circuit tubes	None used.....	Keying diode--V20, 5726/6AL5W.	Keying diode V21, 5726/6AL5W.	Same as B model.
	None used.....	Keying relay control-V21, 6AU6WA.	Keying relay control-V22, 6AH6.	Same as B model.

CHAPTER 2

OPERATING INSTRUCTIONS

Section I. CONTROLS AND INSTRUMENTS

11. General

Haphazard operation or improper setting of the controls can cause damage to electronic equipment. For this reason, it is important to know the function of every control. The actual operation of the equipment is discussed in paragraphs 14 through 24..

12. Transmitter

(fig. 6)

a. *Rf Deck.*

<i>Control or instrument</i>	<i>Function</i>								
P A PLATE meter	Indicates plate current drawn by power amplifier tube.								
P A BAND SWITCH.....	Five-position switch that permits operation of pa tube in bands of: 1.5-2.0 (mc). 2.0-3.0 (mc). 3.0-6.0 (mc). 0.0-11.0 (mc). 11.0-20.0 (mc).								
EXCITATION METER SWITCH and EXCITATION meter	The positions of the switch and the corresponding functions of the meter are as follows: <table style="margin-left: auto; margin-right: auto;"> <thead> <tr> <th style="text-align: center;"><i>Position</i></th> <th style="text-align: center;"><i>Function</i></th> </tr> </thead> <tbody> <tr> <td>MOD PLATE X20</td> <td>Indicates plate current of modulator tubes; reading multiplied by 20.</td> </tr> <tr> <td>INT AMP PLATE X 10</td> <td>Indicates plate current of ipa tube. Reading multiplied by 10.</td> </tr> <tr> <td>P A GRID X2</td> <td>Indicates grid current of pa tube. Reading multiplied by 2.</td> </tr> </tbody> </table>	<i>Position</i>	<i>Function</i>	MOD PLATE X20	Indicates plate current of modulator tubes; reading multiplied by 20.	INT AMP PLATE X 10	Indicates plate current of ipa tube. Reading multiplied by 10.	P A GRID X2	Indicates grid current of pa tube. Reading multiplied by 2.
<i>Position</i>	<i>Function</i>								
MOD PLATE X20	Indicates plate current of modulator tubes; reading multiplied by 20.								
INT AMP PLATE X 10	Indicates plate current of ipa tube. Reading multiplied by 10.								
P A GRID X2	Indicates grid current of pa tube. Reading multiplied by 2.								
FIL VOLTAGE meter	Indicates filament voltage of pa tube.								
TUNING CONTROL.....	Tunes all rf stages except the pa.								
Tuning control frequency dial (mechanical counter)	Indicates transmitting frequency directly in mc on one of four rows of dials. Row (for each band) selected by BAND SELECTOR switch.								
BAND SELECTOR switch	Selects following bands over which the transmitter exciter section operates: 1.5-3.0 mc. 3.0-6.0 mc. 6.0-12.0 mc. 12.0-20.0 mc. Counter containing frequencies in desired band exposed by action of BAND SELECTOR switch.								
SERVICE SELECTOR switch.....	Selects any one of the following five types of operation: Cw AM FSK FSK-AM EXT EXC								
POWER AMPLIFYING TUNING control	Adjusts the pa stage to operating frequency. Initial setting determined from the calibration charts. Final setting found during tuning procedure (par. 17).								
POWER AMPLIFIER LOADING control.....	Adjusts the pa stage to operating frequency. Initial setting determined from the calibration charts. Final setting found during tuning procedure (par. 17).								
POWER AMPLIFIER TUNING and LOADING dials (mechanical counters)	Indicates settings of pa tuning controls.								

b. Modulator Deck

<i>Control or instrument</i>	<i>Function</i>
FILAMENT VOLTAGE control	Adjusts filament voltage for pa tube (indicated on FIL VOLTAGE meter).
MODULATOR BIAS control.....	Sets no-signal modulator plate current (shown on EXCITATION meter in MOD PLATE X20 position).
600 OHM LINE GAIN control.....	Sets audio input level to equipment when using a telephone set.
CARBON MIKE GAIN control	Sets audio input level to equipment when using a carbon mike.
EXCITER PLATE POWER switch (basic model only)	Turns on exciter power supply and removes blocking bias for FSK, FSK-AM, and EXT EXC operation when in on (up) position. Left in OFF position for cw and AM operation, and exciter supply is turned on by PLATE RELAY switch for cw and by closing the mike switch for AM.
KEYING; switch (in lettered models).....	Removes blocking bias for EXT EXC, FSK, or FSK-AM operation when in CONTINUOUS position. In NORMAL position for cw and AM operation.

c. Power Supply Deck.

<i>Control or instrument</i>	<i>Function</i>
FILAMENT POWER circuit breaker	Applies ac line power to equipment when in ON position
PLATE POWER circuit breaker	Applies high voltage to equipment when in ON position and when either the PLATE RELAY switch is in the on (up) position or the mike switch is closed. In either case, the high voltage cannot be turned on until approximately 25 seconds have passed after the FILAMENT POWER circuit breaker is closed.
OVERLOAD RESET switch	When pressed down momentarily restarts equipment after overloads. Normally kept at off (up) position by a spring.
TUNE-OPERATE (TUNE-NORMAL, in A and C models) switch	When set at TUNE, lowers high voltage of equipment. When set at OPERATE (NORMAL in A and C models), applies normal high voltage to equipment.
PLATE RELAY switch	Turns on high voltage when PLATE: POWER circuit breaker and PLATE: I RELAY switch are set at their on (up) positions. In the basic model only, also turns on exciter power supply when set to on position. Switch is left in on position for all services except AM operation. In AM operation, high voltage is obtained by closing the mike switch.
FILAMENT POWER indicator light (green).....	Indicates presence of ac power in equipment.
PLATE POWER indicator light (red)	Indicates high voltage power supply is on.
3 AMP fuse.....	Protects bias supply transformer and blower motor (located on the back panel).
6 AMP fuse.....	Protects filament, low-voltage circuits, and blower motor (located on rf deck).
BLOWN FUSE INDICATORS.....	Indicators for 3 AMP and 6 AMP fuses for blow conditions.

d. Housing Control.

<i>Control or instrument</i>	<i>Function</i>
THERMAL RESET push button switch	Permits manual resetting of thermostat.

13. Antenna Tuning Unit

(fig. 7)

<i>Control or instrument</i>	<i>Function</i>
COUPLING control.....	Varies the amount of current in the antenna.
FREQUENCY control 10 MC-INCREASE-20 MC.	Adjusts the antenna loading to the transmitter in the high-frequency range.
FREQUENCY control 2 MC-INCREASE-10 MC.	Adjusts the antenna loading to the transmitter in the low-frequency range.

AGO 6429A

<i>Control or instrument</i>	<i>Function</i>
ANTENNA CURRENT meter..... Range switch.....	Measures the rf current in the antenna. Three-position switch to match a whip antenna in either the low-frequency (2 to 10 (mc). or high-frequency (10 to 20 (mc). range of the transmitter or to match a long-wire antenna to the 2- to 20 (mc). range of the transmitter.

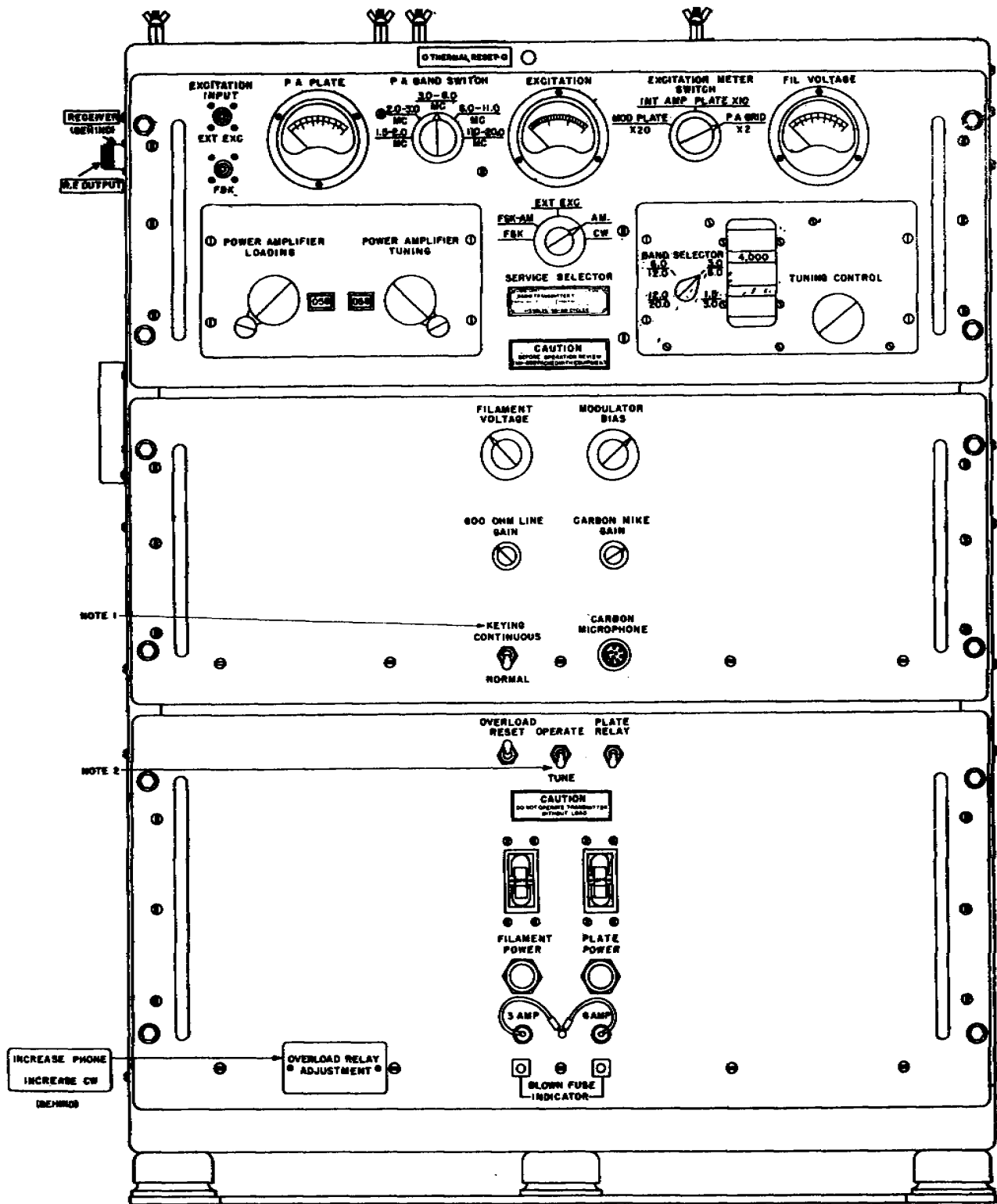

NOTES:
 1. IN BASIC MODEL KEYING SWITCH IS CALLED
EXCITER PLATE POWER WITH OFF IN DOWN
 POSITION

2. IN A AND C MODELS OPERATE POSITION
 IS LABELED NORMAL

TM809-10-N

Figure 6. Transmitter front panel.

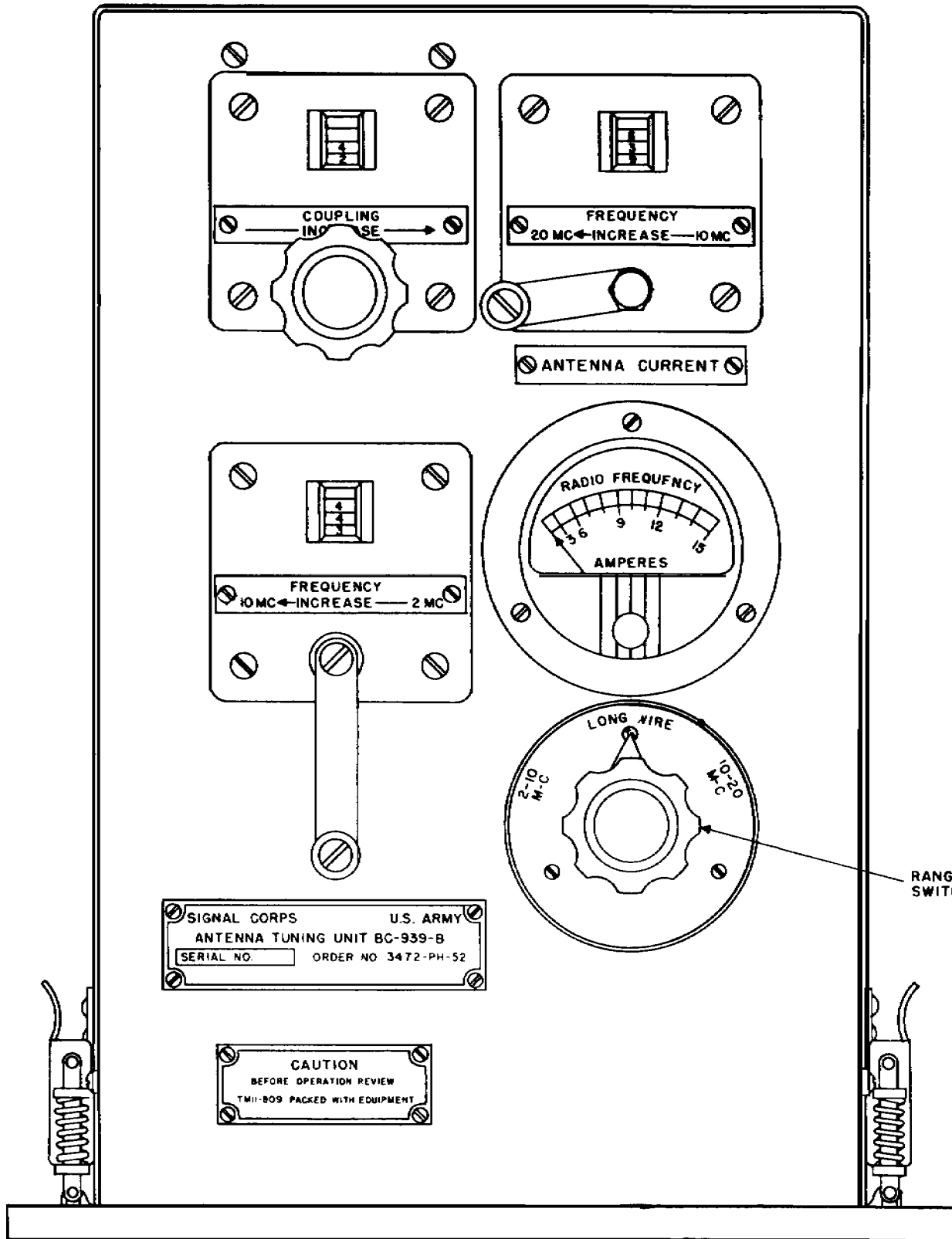

TM809-10-91

Figure 7. Antenna tuning unit front panel.

Section II. OPERATION

14. Checking Connections

The following connections, with the exception of the handkey and carbon microphone, are made during installation. Before operation, however, the operator should, as a matter of routine, check these connections:

a. *Power Input.* Power Cord CD-763 should be connected between the power receptacle (fig. 4) and the ac line.

b. *Antenna.*

(1) The connection from a doublet antenna (if used) to the R.F. OUTPUT receptacle (fig. 5).

(2) When the antenna tuning unit is used, check:

(a) Coaxial cable between the R. F. OUTPUT receptacle (fig. 5) and the input terminals on the side of the tuning unit.

(b) Lead from antenna to antenna terminal at the rear of the tuning unit.

c. *Associated Receiver.* In an installation where an associated receiver uses the same antenna, check the connection at the RECEIVER receptacle (fig. 5).

d. *Cw Transmission.* Connect the handkey to the key jack at the associated control box for the radio set.

e. *AM Transmission.* Connect the carbon microphone cable to the CARBON MICROPHONE receptacle.

f. *EXT EXC Transmission.* Check connection of the external exciter output cable to the EXT EXC receptacle.

g. *FSK Transmission.*

(1) In lettered models used with Radio Modulator MD-239/GR, check the two cables from the EXT EXC and FSK connectors of the transmitter to the MO IN and FSK OUT connectors of the modulator.

(2) When Radio Modulator MD-239/GR is not used, check the connection of the frequency-shift exciter cable to the FSK receptacle.

h. *FSK-AM Transmission.* Make the checks given in e and g(1) or (2) above.

i. *Remote Control Operation.* Where the transmitter is controlled from a junction box (as in

Radio Sets AN/GLQ-2 and AN, GRC- 26D), check the connection to the remote control receptacle (fig. 4).

j. *Jumper Plug.* See that the jumper plug is inserted in its receptacle at the rear of the transmitter (fig. 4).

15. Tuning Charts

a. *Transmitter.*

(1) Figures 8 through 12 show a series of five *tuning* curves for the transmitter operating frequency range of 1.5 to 20 (mc). Figures 13 through 17 show a series of five *loading* curves for the transmitter which are used in the same frequency range. The vertical numbers along the left edge of the charts represent the numbers of the POWER AMPLIFIER TUNING and POWER AMPLIFIER LOADING indicators of the transmitter depending on whether a tuning or a loading chart is being used. The horizontal numbers along the bottom edge of the charts represent the transmitter operating frequency in (mc).

(2) After locating the transmitter operating frequency at the bottom of the chart, follow the line upward to the approximate center of the shaded area of the curve. From this point, follow in a horizontal line to the left edge and note the number intersected. Set the tuning or loading control (whichever adjustment is being made from the appropriate chart) at the number found. Three numbers are exposed on each of the tuning control dials. The first two are whole numbers and the next is in tenths. The tuning control reads up to approximately 25 and the loading control reads up to approximately 30.

b. *Antenna Tuning Unit BC-939-B.* Appropriate control settings for the tuning unit when used with Radio Transmitter T-368(*)/URT are given in (1) and (2) below.

(1) 2-to 10-mc range.

Operating frequency (mc)	Range switch position	COUPLING control setting	Loading (FREQUENCY control, 2 mc to 10 mc)
2.00	2-10	4.9	4.6
2.05	2-10	4.9	7.1
2.10	2-10	5.1	9.4
2.15	2-10	4.9	11.4
2.20	2-10	4.8	13.3
2.25	2-10	4.7	15.1
2.30	2-10	4.6	16.8
2.35	2-10	4.5	18.3
2.40	2-10	4.5	19.8
2.45	2-10	4.6	21.3
2.50	2-10	4.6	22.6
2.55	2-10	4.3	23.9
2.60	2-10	4.3	25.0
2.65	2-10	4.2	26.2
2.70	2-10	4.2	27.3
2.75	2-10	4.2	28.3
2.80	2-10	4.2	29.3
2.85	2-10	4.2	30.2
2.90	2-10	4.5	31.0
2.95	2-10	4.1	32.0
3.00	2-10	4.1	32.7
3.05	2-10	4.1	33.5
3.10	2-10	4.1	34.2
3.15	2-10	4.2	65.0
3.20	2-10	4.2	35.6
3.25	2-10	4.3	36.3
3.30	2-10	4.3	37.0
3.35	2-10	4.5	37.5
3.40	2-10	4.5	38.2
3.45	2-10	4.3	38.7
3.50	2-10	4.2	38.9
3.55	2-10	4.1	39.5
3.60	2-10	4.0	39.9
3.65	2-10	4.0	40.4
3.70	2-10	4.0	40.9
3.75	2-10	4.1	41.3
3.80	2-10	4.1	41.7
3.85	2-10	4.1	42.2
3.90	2-10	4.1	42.5
3.95	2-10	4.2	42.9
4.00	2-10	4.2	43.2
4.05	2-10	4.0	43.7
4.10	2-10	4.0	44.0
4.15	2-10	3.9	44.3
4.20	2-10	3.8	44.6
4.25	2-10	3.8	44.9
4.30	2-10	3.6	45.2
4.35	2-10	3.4	45.5
4.40	2-10	3.4	45.8
4.45	2-10	3.1	46.1
4.50	2-10	2.9	46.2
4.55	2-10	2.9	46.4
4.60	2-10	2.8	46.7
4.65	2-10	2.8	46.9
4.70	2-10	2.8	47.2
4.75	2-10	2.8	47.4
4.80	2-10	2.7	47.6
4.85	2-10	2-7	47.6
4.90	2-10	2-7	47.9
4.95	2-10	2-7	48.1
5.00	2-10	2-7	48.3
5.05	2-10	2-7	48.5
5.10	2-10	2-7	48.7
5.15	2-10	2.6	48.9
5.20	2-10	2.6	49.1
5.25	2-10	2.6	49.3
5.30	2-10	2-5	49.8
5.35	2-10	2-5	50.0
5.40	2-10	2-5	50.1
5.45	2-10	2-5	50.4
5.50	2-10	2-5	50.5

Operating frequency (mc)	Range switch position	COUPLING control setting	Loading (FREQUENCY control, 2 mc to 10 mc)
5.60	2-10	2.5	50.7
5.65	2-10	2.4	50.9
5.70	2-10	2.3	50.9
5.75	2-10	2.3	51.0
5.80	2-10	2.3	51.2
5.85	2-10	2.3	51.3
5.90	2-10	2.3	51.4
5.95	2-10	2.3	51.5
6.00	2-10	2.3	51.7
6.05	2-10	2.3	51.9
6.10	2-10	2.3	51.9
6.15	2-10	2.3	52.0
6.20	2-10	2.3	52.2
6.26	2-10	2.3	52.3
6.30	2-10	2.2	52.5
6.35	2-10	2.2	52.5
6.40	2-10	2.2	52.7
6.50	2-10	2.2	53.0
6.60	2-10	2.1	53..1
6.70	2-10	2.0	53.4
6.80	2-10	2.0	53.6
6.90	2-10	2.0	53.7
7.00	2-10	1.9	543.0
7.10	2-10	1.8	54.2
7.20	2-10	1.8	54.4
7.30	2-10	1.8	54.5
7.40	2-10	1.8	54.7
7.50	2-10	1.7	54.9
7.60	2-10	1.7	55.1
7.70	2-10	1.6	55.2
7.80	2-10	1.6	55.4
7.90	2-10	1.6	55.5
8.00	2-10	1.6	55.7
8.10	2-10	1.5	55.7
8.20	2-10	1.5	55.9
8.30	2-10	1.5	56.1
8.40	2-10	1.5	56.1
8.50	2-10	1.5	56.2
8.60	2-10	1.5	56.4
8.70	2-10	1.5	56.5
8.80	2-10	1.5	56.7
8.90	2-10	1.5	56.8
9.00	2-10	1.5	57.1

Operating frequency (mc)	Range switch position	COUPLING control setting	Loading (FREQUENCY control, 2 mc to 10 mc)
9.10	2-10	1-5	57.3
9.20	2-10	1.5	57.4
9.30	2-10	1.5	57.5
9.40	2-10	1.5	57.7
9.50	2-10	1.5	57.7
9.60	2-10	1.5	57.8
9.70	2-10	1.5	58.0
9.80	2-10	1.4	58.3
9.90	2-10	1.4	58.4
10.00	2-10	1.4	58.5

(2) 10- to 20-mc range.

Operating frequency (mc)	Range switch position	COUPLING control setting	Loading (FREQUENCY control, 2 mc to 10 mc)
10.00	10-20	1.1	2.5
10.10	10-20	1.1	2.7
10.20	10-20	1.1	3.0
10.30	10-20	1.1	3.4
10.40	10-20	1.1	3.7
10.50	10-20	1.1	4.0
10.60	10-20	1.1	4.5
10.70	10-20	1.1	4.7
10.80	10-20	1.1	5.0
10.90-	10-20	1.1	5.3
11.00	10-20	1.1	5.7
11.10	10-20	1.2	5.8
11.20	10-20	1.2	6.1
11.30	10-20	1.2	6.5
11.40	10-20	1.2	6.7
11.50	19-20	1.2	7.0
11.60	10-20	1.2	7.1
11.70	10-20	1.2	7.4
11.80	10-20	1.2	7.7
11.90	10-20	1.2	7.9
12.00	10-20	1.2	8.1
12.10	10-20	1.2	8.4
12.20	10-20	1.1.	8.6
12.30	10-20	1.1	8.8
12.40	10-20	1.1	9.0
12.50	10-20	1.1	9.2
12.60	10-20	1.1	9.5

Operating frequency (mc)	Range switch position	COUPLING control setting	Loading (FREQUENC Y control, 2 mc to 10 mc)
12.70	10-20	1.1	9.8
12.80	10-20	1.1	9.9
12.90	10-20	1.1	10.0
13.00	10-20	1.1	10.3
13.10	10-20	1.1	10.4
13.20	10-20	1.1	10.7
13.30	10-20	1.1	10.8
13.40	10-20	1.1	11.0
13.50	10-20	1.1	11.2
13.60	10-20	1.1	11.3
13.70	10-20	1.1	11.6
13.80	10-20	1.1	11.6
13.90	10-20	1.1	11.8
14.00	10-20	1.1	11.9
14.20	10-20	1.1	12.3
14.40	10-20	1.1	12.4
14.60	10-20	1.1.	12.8
14.80	10-20	1.1	13.0
15.00	10-20	1.1	13.2
15.20	10-20	1.1	13.6
15.40	10-20	1.0	13.8
15.60	10-20	1.0	14.2
15.80	10-20	1.0	14.2
16.00	10-20	1.0	14.4
16.20	10-20	1.0	14.6
16.40	10-20	.9	14.7
16.60	10-20	.9	14.7
16.80	10-20	.8	14.9
17.00	10-20	.8	15.1
17.20	10-20	.8	15.4
17.40	10-20	.7	15.4
17.60	10-20	.5	15.6
17.80	10-20	.4	16.0
18.00	10-20	.4	16.3
18.20	10-20	.4	16.4
18.40	10-20	.4	16.7
18.60	10-20	.3	17.0
18.80	10-20	.3	17.2
19.00	10-20	.3	17.4
19.20	10-20	.3	17.6
19.40	10-20	.2	17.9
19.60	10-20	.2	18.3
19.80	10-20	.2	18.5
20.00	10-20	.1	18.7

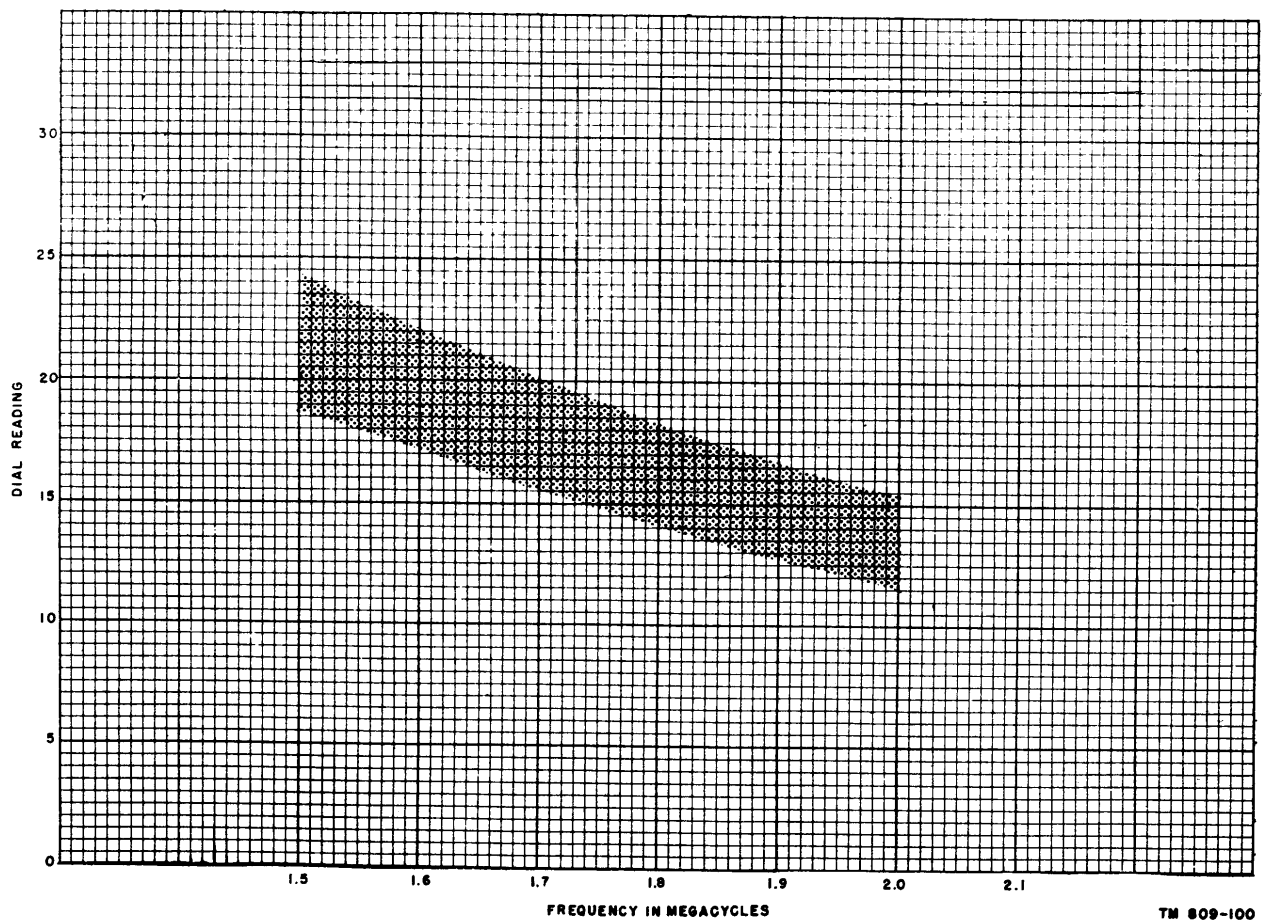

Figure 8. POWER AMPLIFIER TUNING control calibration chart, 1.5 to 2.0 (mc).

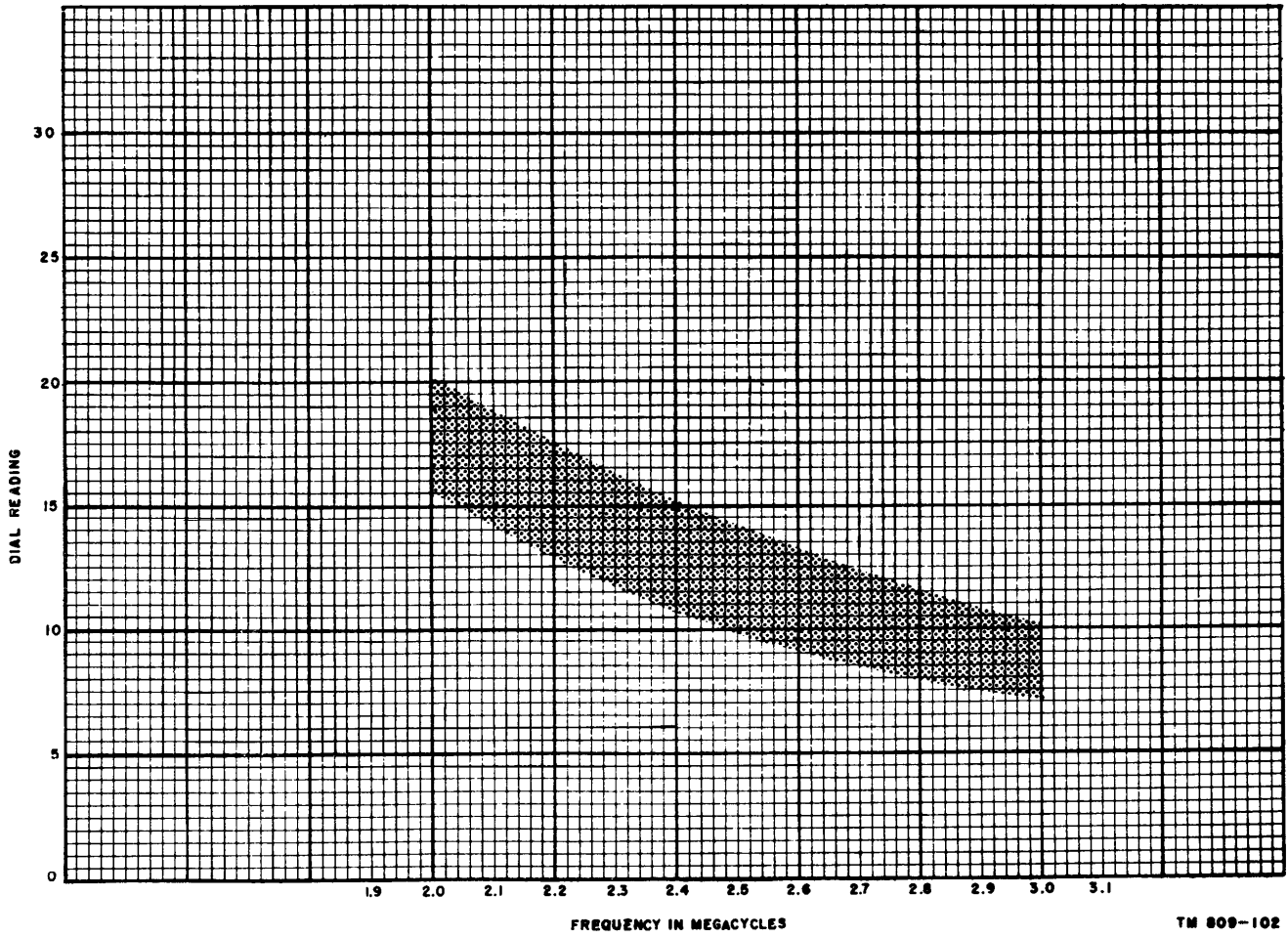
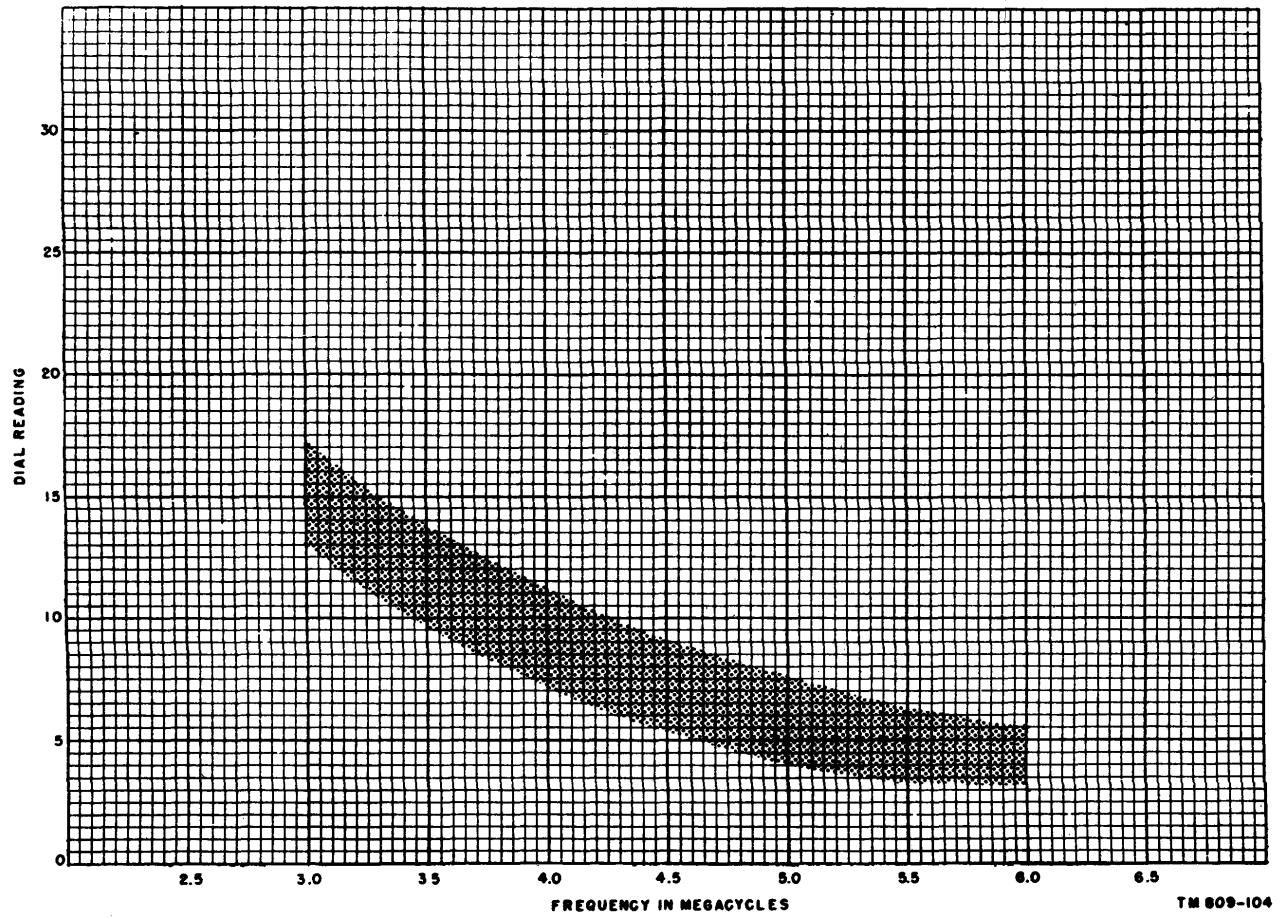

Figure 9. POWER AMPLIFIER TUNING control calibration chart, 2.0 to 3.0 mc.



TM 809-104

Figure 10. POWER AMPLIFIER TUNING control calibration chart, 3.0 to 6.0 mc.

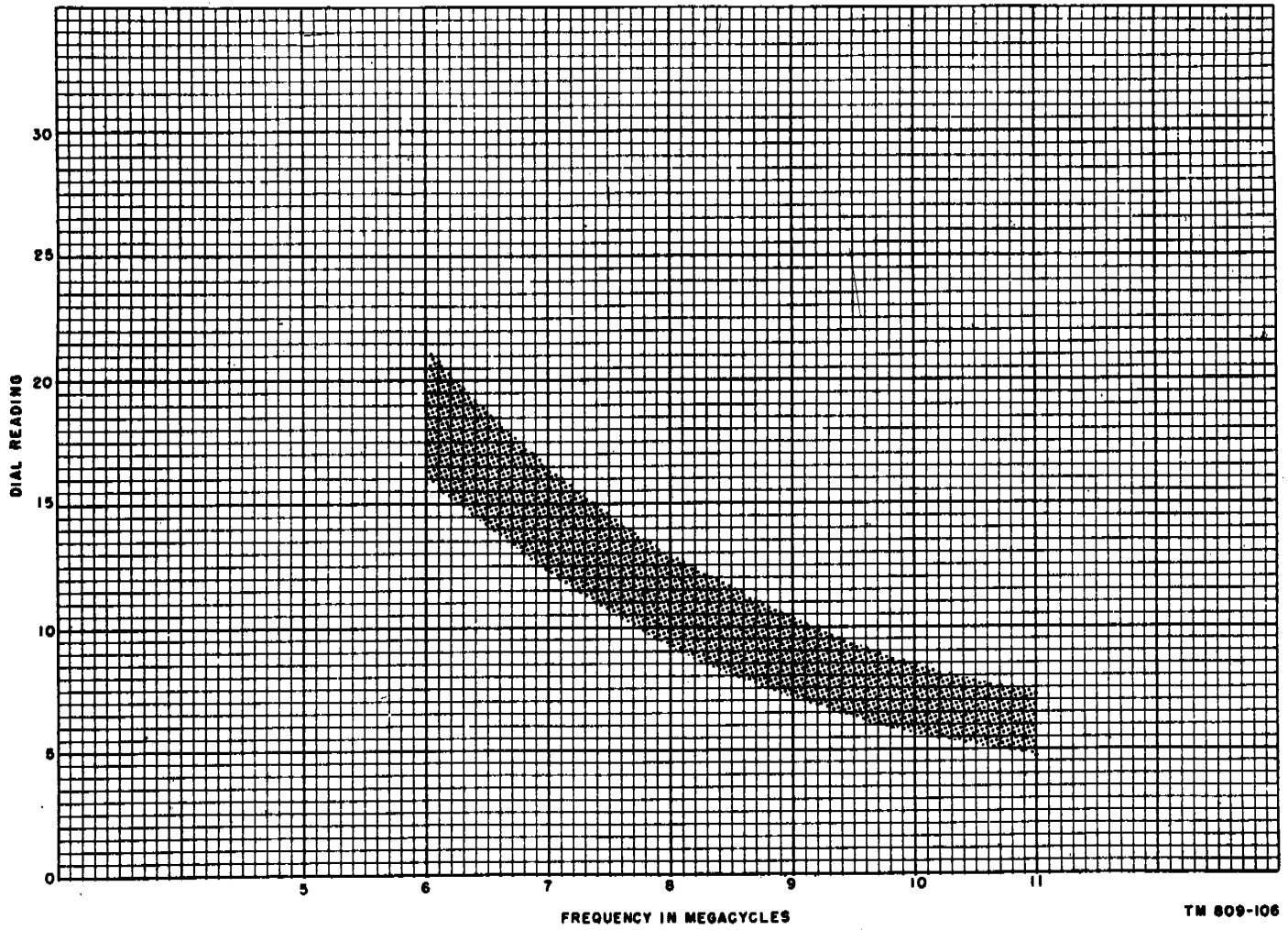

Figure 11. POWER AMPLIFIER TUNING control calibration chart, 6 to 1 mc.

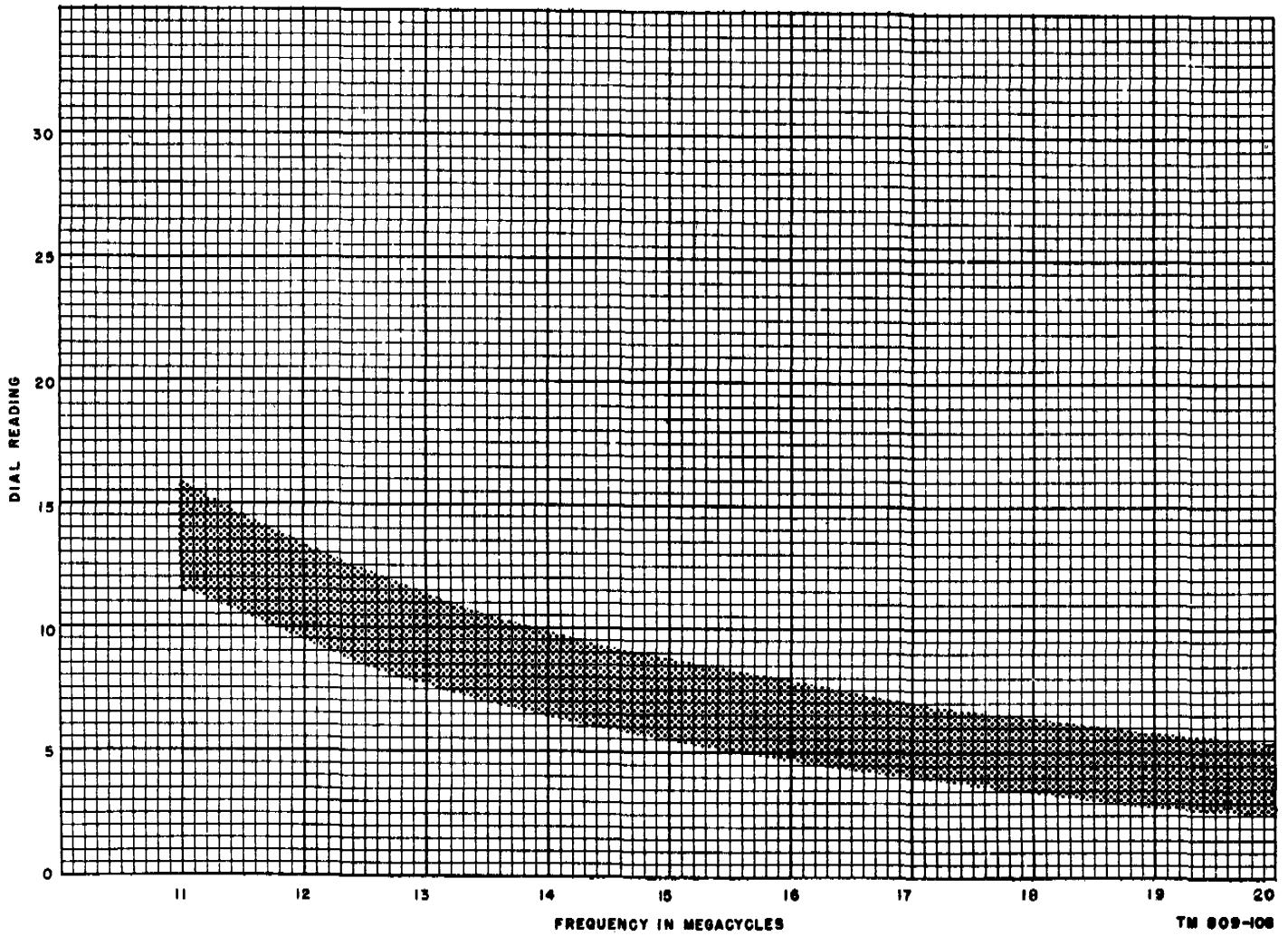
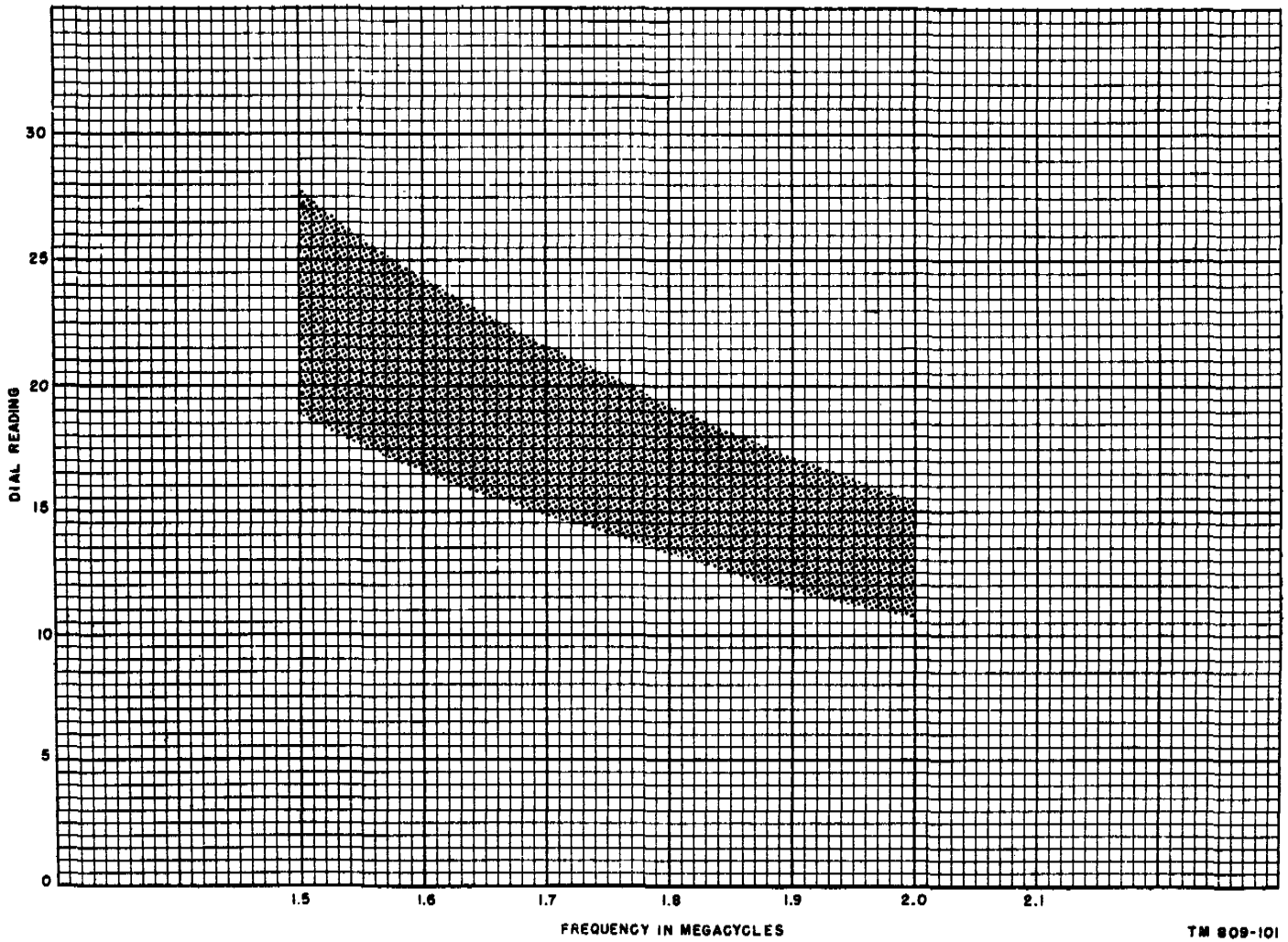

Figure 12. POWER AMPLIFIER TUNING control calibration chart, 11 to 20 mc.



TM 909-101

Figure 13. POWER AMPLIFIER LOADING control calibration chart, 1.5 to 2.0 mc.

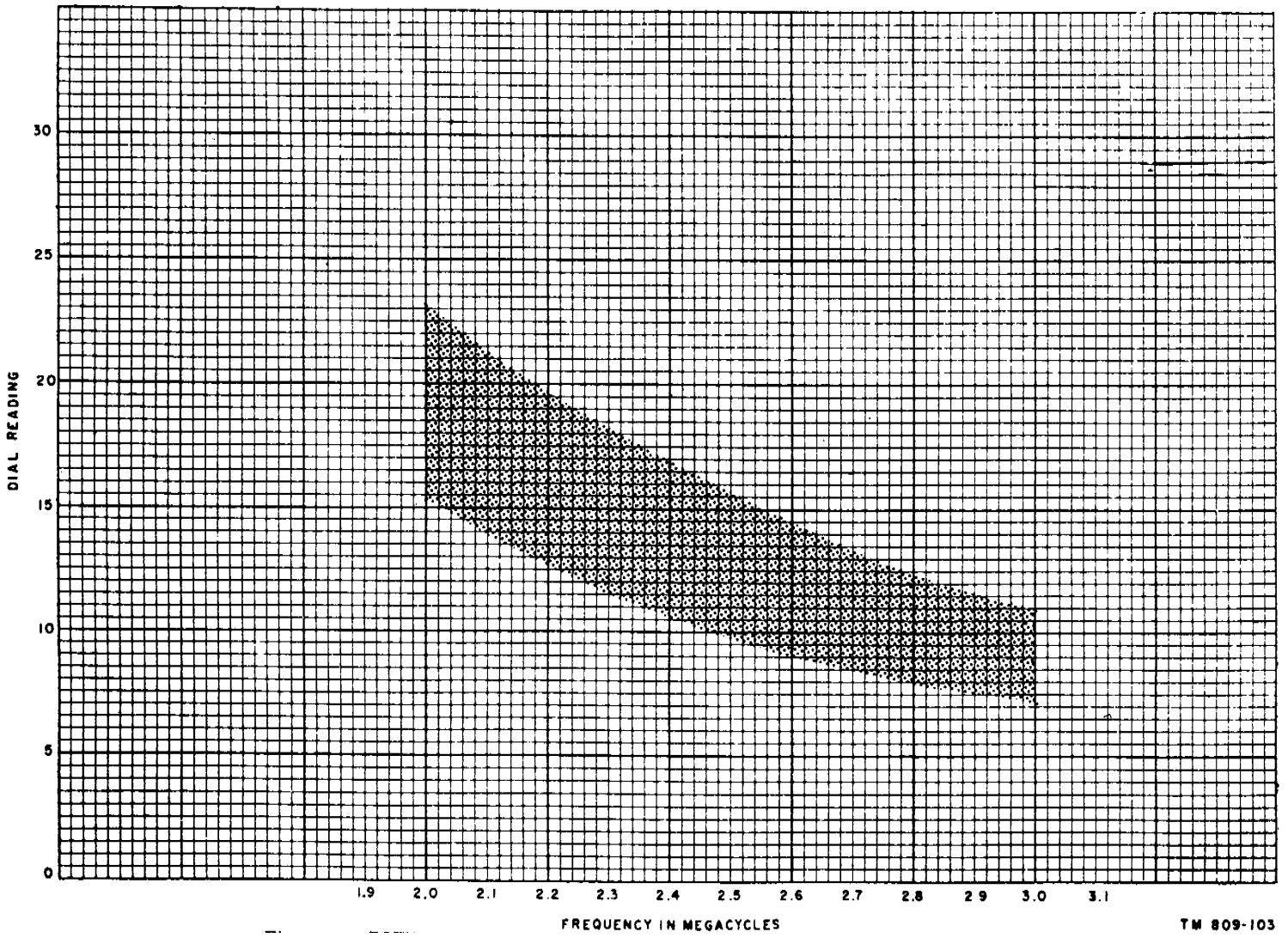

Figure 14. POWER AMPLIFIER LOADING control calibration chart, 2.0 to 3.0 mc.

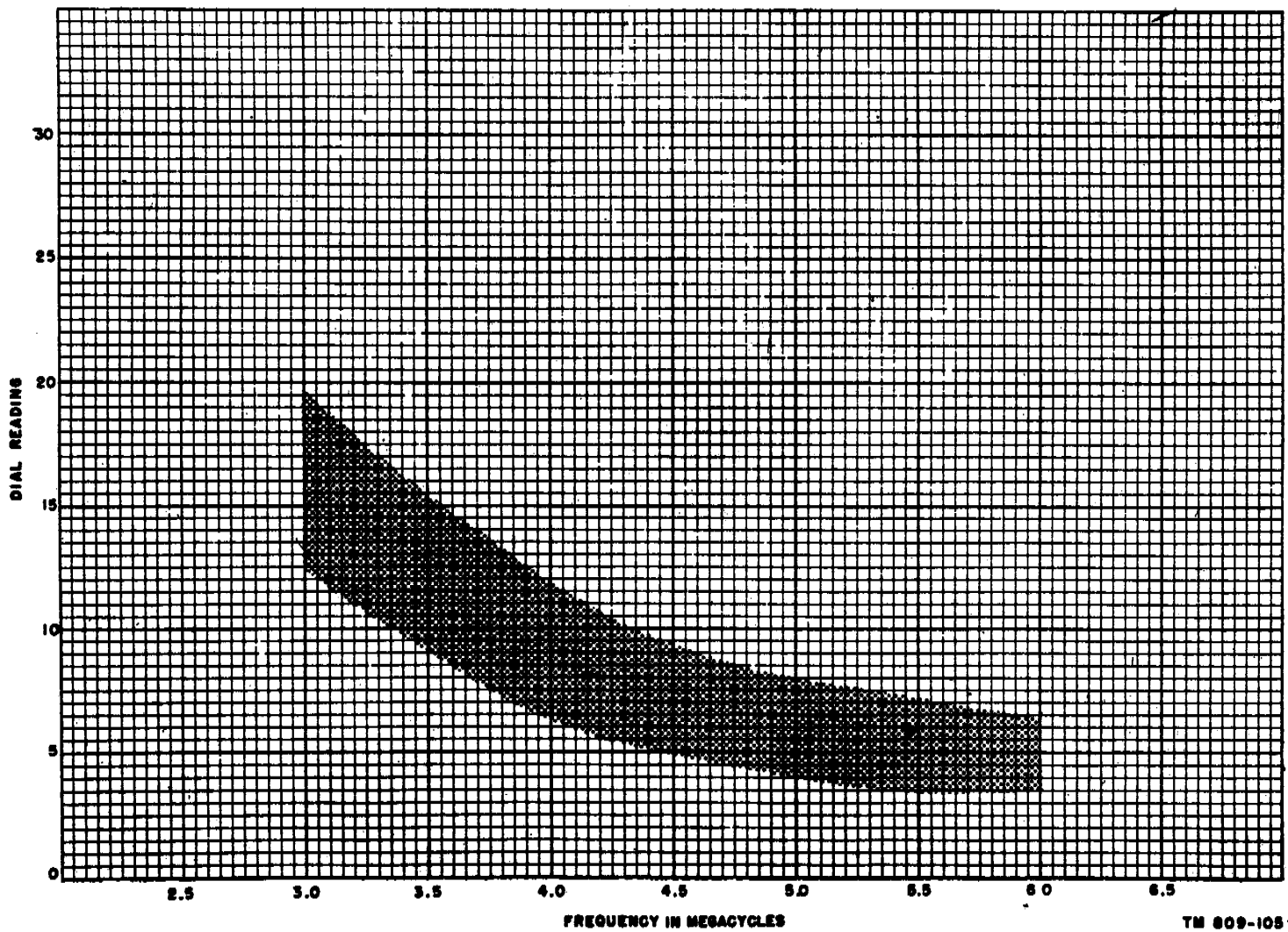
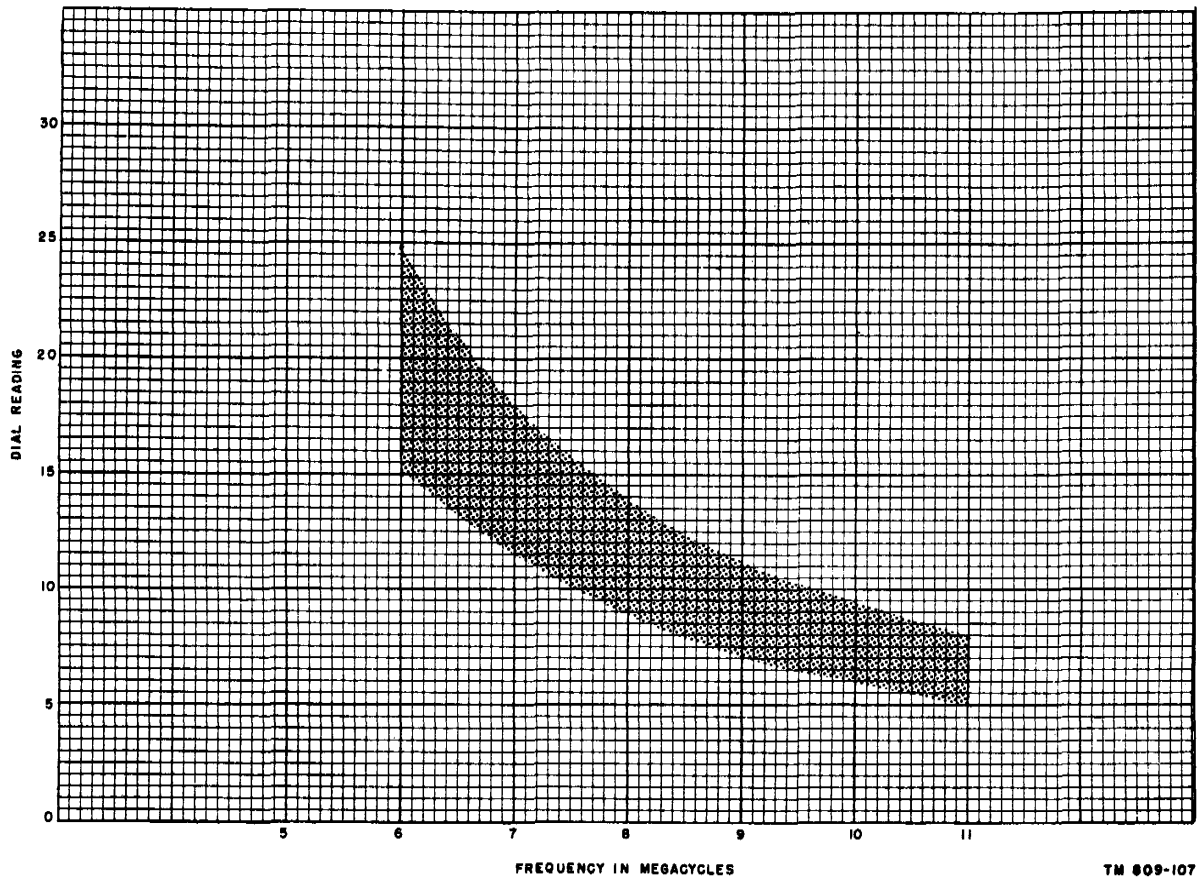

Figure 16. POWER AMPLIFIER LOADING control calibration chart, 3.0 to 6.0 mc.



TM 809-107

Figure 16. POWER AMPLIFIER LOADING control calibration chart, 6.0 to 11.0 mc.

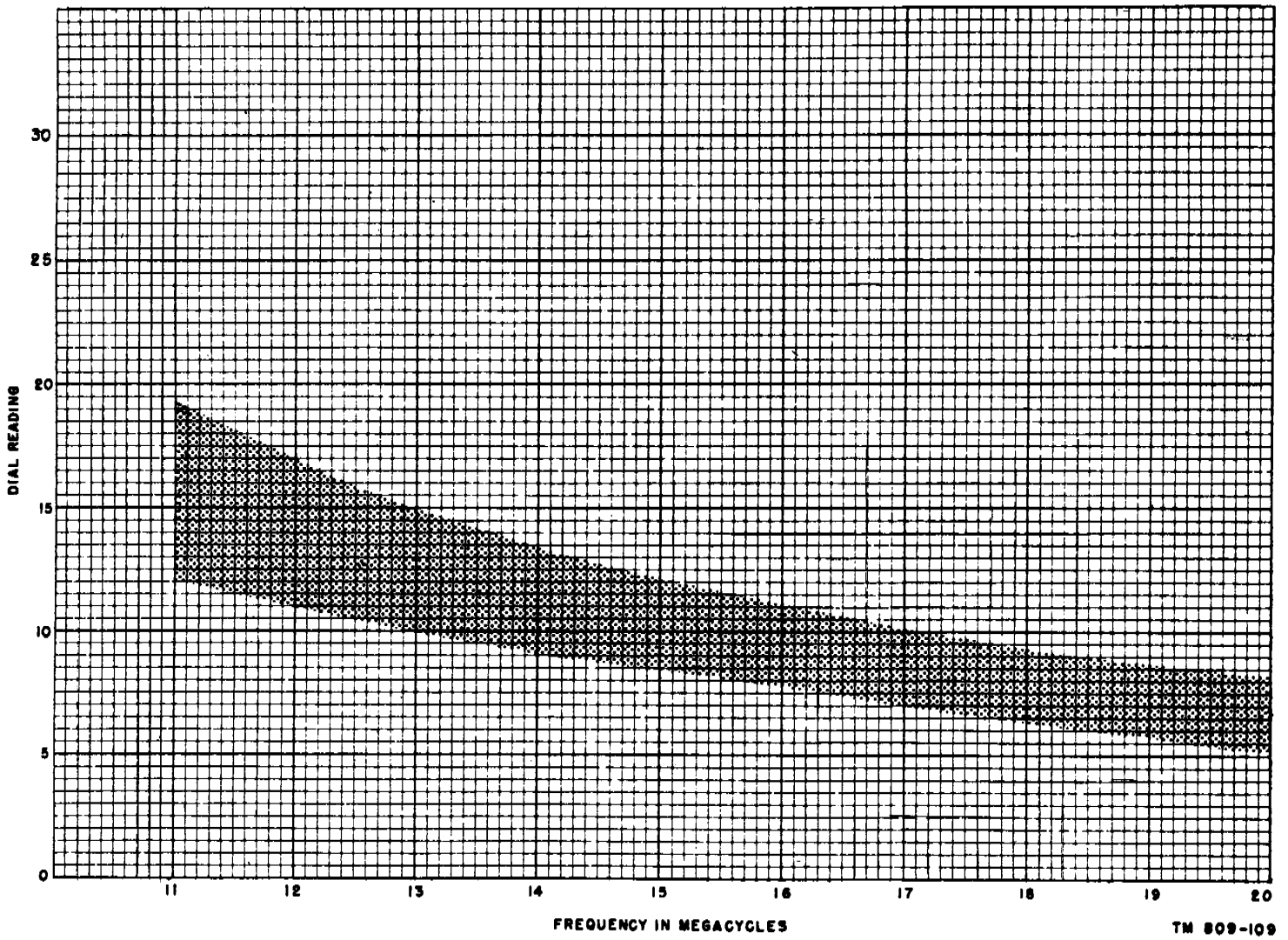

Figure 17. POWER AMPLIFIER LOADING control calibration chart, 11 to 20 mc.

TM 809-109

16. Preliminary Starting Procedure

(fig. 6)

Before starting the equipment, set switches as follows:

- a. Set the FILAMENT POWER circuit breaker to OFF.
- b. Set the PLATE POWER circuit breaker to OFF.
- c. Set the TUNE-NORMAL switch (TUNEOPERATE in basic and B models) to the TUNE position.
- d. Set the PLATE RELAY switch to off (down) .
- e. Set the KEYING switch to the NORMAL, position (EXCITER PLATE POWER switch to OFF in basic model).

17. Tuning Procedure

(fig. 6)

Refer to paragraph 16 for preliminary power control settings before using the tuning procedure.

Caution: Do not operate an unloaded transmitter; serious damage to the equipment will result.

a. *Cw Tuning Procedure.*

- (1) Set the TUNING CONTROL to the desired frequency. Figure 18 shows two positions of the TUNING CONTROL dial. The 1.5-3.0 mc. position uses four digits and reads 1.920 mc. The 6.0-12.0 mc. position uses five digits and reads 11.350 mc. The 3.06.0 mc. and 12.0-20.0 mc. positions also use four and five digits respectively. When the BAND SELECTOR switch is set in the two lower bands, the fourth digit reads either 0 or 5; when the switch is set in the two upper bands, the fourth digit travels through 0 to 9 and the fifth digit remains at 0. When frequencies are selected that do not fall on these exact numbers such as 1.917 or 11.357 mc. interpolation must be used. The transmitter, therefore, must be calibrated as shown in (10) below.
- (2) Set POWER AMPLIFIER TUNING and POWER AMPLIFIER LOADING controls to the numbers that corresponds to the desired frequency (para. 15a).
- (3) Turn the BAND SELECTOR switch to the desired band.
- (4) Turn the P A BAND SWITCH to the desired band.
- (5) Turn the desired BAND SWITCH to Cw
- (6) Throw the FILAMENT POWER circuit breaker to ON.
 - (a) Green FILAMENT POWER indicator lamp lights.
 - (b) FIL VOLTAGE meter shows a reading.
 - (c) Blowers go on.
- (7) Adjust the FILAMENT VOLTAGE control for a reading of 5 to 5.2 volts on the FIL VOLTAGE meter.
- (8) Turn the EXCITATION METER SWITCH to P A GRID X2.
- (9) Set the KEYING switch to the CONTINUOUS position (E X C I T E R PLATE POWER switch to up (on) position in basic model). Reading appears on EXCITATION meter.
- (10) Calibrate the transmitter by using the associated receiver. A typical receiver used in sets with the transmitter is Radio Receiver R-390/URR. Calibrate as follows:
 - (a) Calibrate the receiver to the desired operating frequency by following the calibration instructions in TM 11-856, Radio Receiver R-390/URR.
 - (b) On the receiver, set the BFO switch to the ON position and set the BFO PITCH control to 0.
 - (c) Adjust the transmitter TUNING CONTROL until the signal heard in the receiver is zero beat. The transmitter frequency is now the same as that indicated on the KILOCYCLES CHANGE dial regardless of any small difference from transmitter dial reading.
- (11) Throw the PLATE POWER circuit breaker to ON.
- (12) Throw the PLATE RELAY switch to on (up).

AGO 5429A

- (a) Red PLATE POWER indicator lamp lights.
- (b) P A PLATE meter shows a reading.
- (13) Adjust the POWER AMPLIFIER TUNING control to resonance (tuning to the desired frequency) as indicated by the minimum reading on the P A PLATE meter.
- (14) Adjust the POWER AMPLIFIER LOADING control to obtain a reading of 160 milliamperes (ma) on the P A PLATE meter.
- (15) Readjust the POWER AMPLIFIER TUNING control for a minimum reading on the P A PLATE meter.
- (16) Readjust the POWER AMPLIFIER LOADING control for the 160-ma reading on the P A PLATE meter.

Note. For the procedures in (13) through (16) above, the numbers of the tuning controls may be changed so that they do not all in the approximate center of the shaded areas of the calibration charts. This is permissible as long as they remain inside the shaded areas.

- (17) Throw the TUNE-OPERATE switch to OPERATE (TUNE-NORMAL switch to NORMAL in A and C models).
- (a) P A PLATE meter should read approximately 360 ma. If not, repeat the procedures in (16) and (16) above until 360 ma is obtained.
- (b) EXCITATION meter should indicate a reading of 8 to 12 ma at P A GRID X2 position.
- (c) Turn the EXCITATION METER SWITCH to INT AMP PLATE X10 position and EXCITATION meter reading should be between 20 and 70 ma.

Caution: Be sure 70 ma is not exceeded, because the life of the intermediate power amplifier (ma) tube will be reduced considerably.

- (d) FIL VOLTAGE meter should read 6 to 6.2 volts. If not, repeat the procedure in (7) above.

b. ATM Tuning Procedure.

- (1) Follow the tuning procedure for cw (a above) with the following exceptions:
 - (a) For the procedure in a(5) above, turn the SERVICE SELECTOR switch to AM.
 - (b) For the procedure in a(14) above, adjust the POWER AMPLIFIER LOADING control for a 126-ma reading on the P A PLATE meter.
 - (c) For the procedures in a(17) (a) through (d) above, the P A PLATE meter should read a maximum of 275 ma.
- (2) Turn the EXCITATION METER SWITCH to the MOD PLATE X20 position.
- (3) Adjust the MODULATOR BIAS control until a reading of 60 ma is obtained on the EXCITATION meter.
- (4) Now talk normally into the microphone and check for a maximum reading of 230 ma on the EXCITATION meter. If 230 ma is not exceeded on peaks, the transmitter is adjusted for 100 percent modulation with peak clipping control for modulation over 100 percent.

c. EXT EXC Tuning.

- (1) Follow the cw tuning procedure in a(1) through (8) above but turn the SERVICE SELECTOR switch to EXT EXC (a(6) above).
- (2) Set the tuning control on the external exciter source for the desired frequency. The transmitter accepts signals in the frequency range of 1.6 to 20.0 mc. in the EXT EXC position.
- (3) Turn on the external exciter unit.
- (4) Calibrate the external exciter unit.
- (5) Set the KEYING switch to the CONTINUOUS position (EXCITER PLATE POWER switch up in basic model).
- (6) Adjust the TUNING CONTROL for a maximum reading on the EXCITATION meter (8 ma minimum).
- (7) Follow the cw tuning procedure in a(11) through (17) above.
- (8) The transmitter is now tuned for EXT EXC operation.

d. *FSK Tuning.* The tuning procedure is identical with the EXT EXC tuning procedure except that the SERVICE SELECTOR switch must be turned to FSK. For FSK tuning, the following conditions must be observed:

- (1) Be sure that the FSK exciter is turned on before throwing the KEYING switch to the CONTINUOUS position (EXCITER PLATE POWER switch up in basic model).
- (2) The transmitter accepts signals in the 1.5- to 6.0-mc range only.
- (3) During operation of the radioteletype system, the frequency of the transmitted mark signal is lowered 850 cycles to

produce a spacing signal (as in Frequency Shift Exciter 0-39/TRA). The frequency of the transmitted mark signal may range from 1.6 to 20 mc. Since the frequency range of the exciter is limited to a lower range, transmission at higher frequencies involves frequency multiplication in the transmitter. To limit the frequency shift to 850 cycles, it is necessary to reduce the amount of frequency shift supplied by the exciter. The frequency shift and multiplication factor involved for different ranges of transmitter frequency are shown in the table below.

Exciter frequency (mc)	Transmitter frequency (mc)	BAND SELECTOR switch position	Transmitter multipliers used	Transmitter multiplication	Exciter frequency shift (cps)
1.5-3.0	1.5- 3.0	1.5- 3.0	None	X1	850
	3.0- 6.0	3.0- 6.0	1	X2	425
3.0-6.0	6.0 12.0	6.0 12.0	2	X4	212.
	3.0- 6.0	3.0- 6.0	None	X1	850
	6.0-12 .0	6.0-12 .0	1	X2	425
	12.0-20.0	12.0-20.0	2	X4	212.5

e. *FSK-AM Tuning.*

- (1) Tune the transmitter in the FSK position (*d* above).
- (2) Turn the SERVICE SELECTOR switch to the FSK-AM position.

f. *Tuning Procedure of Antenna Tuning Unit BC-939-B* (fig. 7).

Warning: Extremely high rf voltages are present on the antenna tuning unit when the transmitter is in operation. Painful burns will result upon contact.

(1) *Whip antenna.*

- (a) Follow the cw tuning procedure in *a(1)* through (8) above.
- (b) Turn the COUPLING control to the setting that corresponds to the desired frequency (par. 15b).
- (c) Turn the FREQUENCY control to the setting (par. 15b) corresponding to the desired frequency.
- (d) Set the range switch to the position corresponding to the desired frequency.

- (e) Follow the cw tuning procedure in *a(9)* through (17) above, but use the FREQUENCY control of the tuning unit instead of the POWER AMPLIFIER LOADING control.
- (f) A maximum reading on the ANTENNA CURRENT meter indicates the correct tuning procedure.
- (g) If the minimum P A PLATE meter reading is above or below 350 ma, alternately decrease or increase the COUPLING control to obtain this reading. Repeat the procedures in *a(17)* (*a*) above until maximum rf current occurs on the ANTENNA CURRENT meter.

2) *Long-wire antenna.* The tuning procedure for the long-wire antenna is identical with the whip antenna tuning procedure except for the following differences:

- (a) Set the COUPLING control at about 2.0.
- (b) Set the range switch at LONG WIRE.

AGO 5429A

- (c) Turn the FREQUENCY control that covers the low-frequency range to about the center of its range. The exact settings of the COUPLING and FREQUENCY controls will be found in the tuning procedure as indicated by a maximum reading on the ANTENNA CURRENT meter.

Note. If the tuning or loading numbers of the POWER AMPLIFIER TUNING and POWER AMPLIFIER LOADING indicators of the transmitter are not the same as those within the shaded area of the chart being used, it is an indication that the whip or long-wire antenna does not furnish a proper load to the transmitter. Check the antenna for proper length at the operating frequency being used.

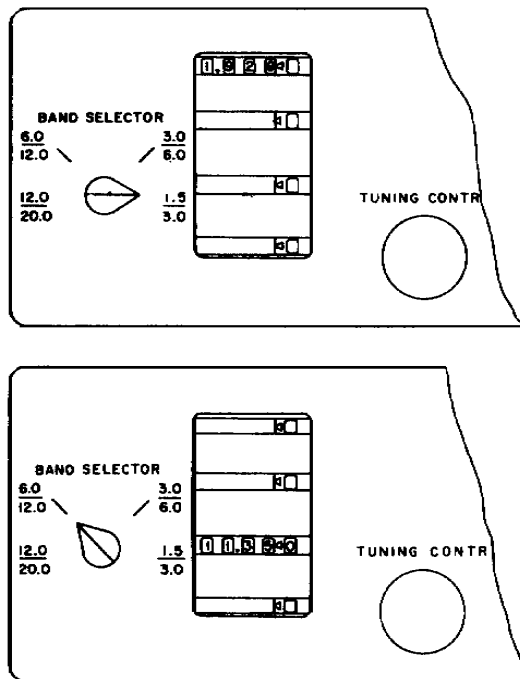

Figure 18. TUNING CONTROL dial, 1.5-3.0 mc 6.0-12.0 mc band position.

18. Starting Procedure

(fig. 6)

If the transmitter is being energized initially or if the frequency of operation is being changed, follow the procedures outlined in paragraphs 16 and 17. If the transmitter is to be operated at the frequency last used before the equipment was shut down, perform the following:

- Set the FILAMENT POWER circuit breaker to OFF.
- Set the PLATE POWER circuit breaker to ON.
- Set the KEYING switch to NORMAL (EXCITER PLATE POWER switch OFF in basic model).
- Set the PLATE RELAY switch to on (up)
- Set the FILAMENT POWER circuit breaker to ON.
 - Green FILAMENT POWER indicator lights.
 - Blowers go on.
 - Red PLATE POWER indicator lights approximately 25 seconds later.

Note. In all types of operation the FILAMENT POWER and PLATE POWER circuit breakers are left at ON while the KEYING (EXCITER PLATE POWER switch in basic model) and PLATE RELAY switches will be on or off, depending on the type of operation desired.

19. Cw Operation

(fig. 6)

Follow the starting procedure (par. 18) before performing cw operation.

- Check to see that the SERVICE SELECTOR switch is at cw.
- Throw the KEYING switch to NORMAL (EXCITER PLATE POWER switch to OFF in basic model).
- Throw the PLATE RELAY switch to on(up) .
- Close the handkey.

20. AM Operation

(fig. 6)

Follow the starting procedure (par. 18) before performing AM operation.

- Check to see that the SERVICE SELECTOR switch is at AM.
- Throw the KEYING switch to NORMAL (EXCITER PLATE POWER to OFF in basic model) .
- Throw the PLATE RELAY switch to off (down)
- Press the microphone switch

21. EXT EXC Operation

(fig. 6)

Follow the starting procedure (par. 18) before performing EXT EXC operation.

- a. Check to see that the SERVICE SELECTOR switch is at EXT EXC.
- b. Turn on the external exciter unit.
- c. Turn the KEYING switch to the CONTINUOUS position (EXCITER PLATE POWER switch to on (up) in basic model).
- d. Turn the PLATE RELAY switch to on (up) .

22. FSK Operation

(fig. 6)

Follow the starting procedure (par. 18) before performing FSK operation.

- a. Check to see that the SERVICE SELECTOR switch is at FSK.
- b. Turn on the frequency-shift exciter unit.
- c. Set the KEYING switch to the CONTINUOUS position (EXCITER PLATE POWER switch to on (up)) and check for a reading on the EXCITATION meter at P A GRID X2 position.
- d. Turn PLATE RELAY switch to on (up).
- e. Key the frequency-shift exciter unit.

23. FSK-AM Operation

(fig. 6)

Follow the starting procedure (par. 18) before performing FSK-AM operation.

- a. Check to see that the SERVICE SELECTOR switch is at FSK-AM.
- b. Turn on the external exciter unit.
- c. Set the KEYING switch to CONTINUOUS (EXCITER PLATE POWER switch to on (up) in basic model) and check for a power amplifier grid current reading.
- d. Turn the PLATE RELAY switch to on (up).
- e. Key the frequency-shift exciter and talk into the microphone.

24. Stopping Procedure

(fig. 6)

To stop the equipment, throw the FILAMENT POWER circuit breaker to OFF. The PLATE POWER circuit breaker is normally kept at ON unless the equipment is to be shut down completely. For standby operation of short periods, leave the FILAMENT POWER circuit breaker at ON but turn the PLATE POWER circuit breaker to OFF, the EXCITER PLATE POWER to OFF (KEYING switch to NORMAL in lettered models), and the PLATE RELAY switch to off (down).

CHAPTER 3 MAINTENANCE INSTRUCTIONS

25. Scope Operator's Maintenance

a. Following is a list of maintenance duties normally performed by the operator of Radio Transmitter T-368(*)/URT. These procedures do not require special tools or test equipment.

b. Operator's maintenance consists of the following:

- (1) Preventive maintenance (par. 26).
- (2) Visual inspection (par. 27).
- (3) Operational checklist (par. 28).
- (4) Replacement of defective indicator lamps.
- (5) Replacement of defective fuses.
- (6) Checking cable connections (par. 14).

26. Preventive Maintenance

(figs.19 and 20)

DA Form 11-238 is a preventive maintenance checklist to be used by the operator and the unit repairman. Figures 19 and 20 show the form as used by the operator and all second and third echelon inspection items are lined out. Items not applicable to the transmitter and antenna tuning unit are also lined out. Instructions for use appear on the form.

27. Visual Inspection

a. When the equipment fails to perform properly, turn off the power and check all the items listed below.

- (1) Improperly connected power cord.
- (2) Worn, broken, or disconnected cords or plugs.

- (3) Blown fuses or tripped circuit breaker.
- (4) Switches (or other controls) set incorrectly.
- (5) Knobs of band switches, tuning controls or antenna tuning unit controls loose on shaft.
- (6) Jumper plug loose or out of receptacle at rear of transmitter (fig. 4).

b. If the above checks do not locate the trouble, proceed to the operational checklist (par. 28).

28. Operational Checklist

a. General. The operational checklist consists only of preliminary starting and operating procedures. The corrective measures listed encompass those the operator can perform. If the measures suggested do not restore normal equipment performance or if the tuning procedures of paragraph 17 do not correct the trouble, troubleshooting by a Field Radio Mechanic is required. Note on the repair tag what corrective measures were taken and how the equipment performed at the time of failure.

b. Procedure. If the transmitter is being energized initially or if the frequency of operation is changed, follow the procedures outlined in paragraphs 16 and 17. If the transmitter is to be operated at the frequency last used before the equipment was shut down, perform the procedures of paragraph 18*a* through *d*. Perform the operations in *c* below in the order given. then follow the tuning procedures (par. 17) for the desired mode of operation.

ADDITIONAL ITEMS FOR 2D AND 3D ECHELON INSPECTIONS		CONDITION	MAINTENANCE CHECK LIST FOR SIGNAL EQUIPMENT SOUND EQUIPMENT, RADIO, DIRECTION FINDING RADAR, CARRIER, RADIOSONDE AND TELEVISION (AR 750-653)																									
26. INSPECT ANTENNA FOR IDENTIFICATION, CORROSION, LOOSE FIT, DAMAGED INSULATORS AND RELEASERS.			EQUIPMENT NOMENCLATURE RADIO TRANSMITTER T-36B QUT																									
27. CHECK FOR NORMAL OPERATION.																												
28. REPORT ON PWR CRATERING. REMOVE BATTERIES.																												
IF DEFICIENCIES NOTED ARE NOT CORRECTED DURING THE INSPECTION, INDICATE ACTION TAKEN FOR CORRECTION. ITEM T- CORD CD 763 (POWER CABLE) FRAYED. REPORTED TO 2D ECHELON MAINTENANCE FOR REPAIR.			EQUIPMENT SERIAL NUMBER 427																									
			INSTRUCTIONS																									
			This form may be used for a period of one month by using the correct dates and weeks of the month. It is to be used as a Preventive Maintenance check list for Signal equipment in actual use, or for a check on equipment prior to issue.																									
			<ol style="list-style-type: none"> For detailed Preventive Maintenance instructions see: <ol style="list-style-type: none"> The Technical Manual (in TM II series) for the equipment. (See DA Pamphlet Number 310-4) The Supply Bulletin (SB II-100 series) for the equipment. (See DA Pamphlet Number 310-4) The Department of the Army Lubrication Order. (See DA Pamphlet Number 310-4) The following action will be taken by either the Communications Officer/Chief for 1st echelon, or the Inspector for higher echelon: <ol style="list-style-type: none"> Enter Equipment Nomenclature and Serial Number. Strike out items that do not apply to the equipment. Operator/Inspector will enter in the columns entitled CONDITION, on the proper line, a notation regarding the condition, using symbols specified under LEGEND. After operator completes each daily inspection he will initial over the appropriate dates under "Daily Condition for Month", then return form to his supervisor. 																									
			TYPE OF INSPECTION																									
		<table border="1"> <thead> <tr> <th>OPERATOR</th> <th>1/3 ECHELON</th> <th>DATE</th> <th>SIGNATURE</th> </tr> </thead> <tbody> <tr> <td>✓</td> <td></td> <td>10 FEB</td> <td>CPL Roy & Barick</td> </tr> <tr> <td></td> <td></td> <td></td> <td></td> </tr> <tr> <td></td> <td></td> <td></td> <td></td> </tr> <tr> <td></td> <td></td> <td></td> <td></td> </tr> <tr> <td></td> <td></td> <td></td> <td></td> </tr> </tbody> </table>			OPERATOR	1/3 ECHELON	DATE	SIGNATURE	✓		10 FEB	CPL Roy & Barick																
OPERATOR	1/3 ECHELON	DATE	SIGNATURE																									
✓		10 FEB	CPL Roy & Barick																									

DA FORM 11-238
MAY 57

REPLACES DA FORM 11-238, 1 NOV 55; 11-239, 11-244, 11-245, 11-246, 11-249, 11-250, AND 11-251, WHICH ARE OBSOLETE

TM809-10-1

LEGEND for marking conditions:
 Satisfactory, ✓.
 Adjustment, Repair or Replacement required, X.
 Defect corrected, (X).

DAILY CONDITION FOR MONTH OF

NO.	DAILY ITEM	DAILY CONDITION FOR MONTH OF																																	
		1	2	3	4	5	6	7	8	9	10	11	12	13	14	15	16	17	18	19	20	21	22	23	24	25	26	27	28	29	30	31	2D 3D ECH- ELON		
1.	COMPLETENESS AND GENERAL CONDITION OF EQUIPMENT. (Transmitter, antenna, cables, microphones, tubes, spare parts, technical manuals).	✓	✓	✓	✓	✓	✓	✓	✓	✓	✓	✓	✓	✓	✓	✓	✓	✓	✓	✓	✓	✓	✓	✓	✓	✓	✓	✓	✓	✓	✓	✓	✓	✓	
2.	CLEAN DIRT AND MOISTURE FROM MICROPHONES, KEYS, JACKS, PLUGS, COMPONENT PANELS.	✓	✓	✓	✓	✓	✓	✓	✓	✓	✓	✓	✓	✓	✓	✓	✓	✓	✓	✓	✓	✓	✓	✓	✓	✓	✓	✓	✓	✓	✓	✓	✓	✓	
3.	INSPECT CONTROLS FOR NORMAL OPERATION.	✓	✓	✓	✓	✓	✓	✓	✓	✓	✓	✓	✓	✓	✓	✓	✓	✓	✓	✓	✓	✓	✓	✓	✓	✓	✓	✓	✓	✓	✓	✓	✓		
4.	CHECK FOR NORMAL OPERATION OF EQUIPMENT. BE ALERT FOR UNUSUAL OPERATION OR CONDITION.	✓	✓	✓	✓	✓	✓	✓	✓	✓	✓	✓	✓	✓	✓	✓	✓	✓	✓	✓	✓	✓	✓	✓	✓	✓	✓	✓	✓	✓	✓	✓	✓		

NO.	WEEKLY ITEM	CONDITION EACH WEEK						2D 3D ECH	ADDITIONAL ITEMS FOR 2D AND 3D ECHELON INSPECTIONS	CONDITION
		1ST	2D	3D	4TH	5TH	6TH			
5.	CLEAN AND REMOVE EXTERIORS OF CASES, MOUNTS, ANTENNAS, ETC.	✓							15. INSPECT SEAMS AND JOINTS FOR CRACKS, CORROSION, AND WEAR.	
6.	INSPECT CASES, MOUNTS, ANTENNAS AND EXPOSED METAL SURFACES FOR RUST, CORROSION.	✓							16. INSPECT RELAYS AND CONTACTS FOR WEAR, BURNING, AND CORROSION.	
7.	INSPECT CORDS, CABLE, WIRE, SHOCK MOUNTS FOR CUTS, KINKS, BREAKS, FRAYING, UNDUCE STRAIN.	X							17. INSPECT WINDING OF COILS FOR SHORTS AND WEAR.	
8.	INSPECT SWITCHES AND CONTACTS FOR WEAR, BURNING, AND CORROSION.								18. INSPECT RESISTORS, CAPACITORS AND INDUCTORS FOR CRACKS, BURNING, AND WEAR.	
9.	INSPECT TUBES AND VACUUM TUBES FOR WEAR, BURNING, AND CORROSION.								19. CLEAN AND OIL CONTACTS, TERMINALS, AND SLIDERS.	
10.	INSPECT ACCESSIBLE ITEMS FOR LOOSE NUTS, SWITCHES, KNOBS, JACKS, CONNECTORS, PILOT LIGHTS, CABLES, ETC.	✓							20. INSPECT TERMINALS AND CONTACTS FOR WEAR, CORROSION, AND CRACKS.	
11.	CLEAN AND/OR INSPECT AIR FILTERS, BRASS NAME PLATES, DIAL AND METER WINDOWS.	✓							21. INSPECT TERMINALS OF LARGE PIPES FOR WEAR AND CORROSION.	
12.	INSPECT BATTERIES FOR LEAKAGE, CORROSION, AND WEAR.								22. INSPECT TRANSFORMERS, CHOKES, POTENTIOMETERS AND RESISTORS FOR OVERHEATING AND DISCOLORATION.	
ADDITIONAL ITEMS FOR 2D AND 3D ECHELON INSPECTIONS								CONDITION		
13.	INSPECT ENCLAVES AND COVERS FOR WEAR, CORROSION, AND CRACKS.								23. INSPECT GENERATORS, IMPEDANCE, AND CAPACITORS FOR STUCK WEAR, SPRING TENSION, AND FITTING OF SUBSTITUTION.	
14.	INSPECT TERMINALS AND CONTACTS FOR WEAR, CORROSION, AND CRACKS.								24. INSPECT BATTERIES FOR WEAR, CORROSION, AND CRACKS.	
									25. INSPECT WATERPROOF COVERS FOR WEAR, CORROSION, AND CRACKS.	

CONTINUED ON PAGE 4

c. Operational Checklist

	Action	Normal Indication	Corrective
<p><i>PREMINARY STARTING AND OPERATING PROCEDURE</i></p>	1. Set FILAMENT POWER circuit breaker on.	Green light lights Blowers go on	Check FILAMENT POWER Press THERMAL RESET button. Refer to paragraph 27.
	2. Set EXCITATION METER switch to MOD PLATE X20 position. meter.	FIL VOLTAGE meter indicates 5 to 5.2 volts. Red PLATE POWER lamp lights in approximately 25 seconds P A PLATE meter shows low reading	Adjust FILAMENT VOLTAGE control. Check OVERLOAD RESET. Check PLATE POWER lamp. Refer to paragraph 27. Higher echelon repair required.
	3. Set PLATE POWER circuit breaker and PLATE RELAY switch to off meter reading drops to zero.(down) positions.	Approximately 50-ma reading on EXCITATION meter. Red light goes off and PA PLATE meter reading drops to zero.	Adjust MODULATOR BIAS control. Higher echelon repair required.
	4. Set EXCITATION METER switch to PAGRID X2 position and set KEYING switch to CONTINOUS position (EXCITER PLATE POWER switch on (up) in basic model).	8-ma minimum reading on EXCITATION meter.	Higher echelon repair required.
	5. Set EXCITATION METER switch to INT AMP PLATE X10 position	20- to 70-ma reading on EXCITION meter.	Higher echelon repair required..

CHAPTER 4 SHIPMENT AND LIMITED STORAGE AND DEMOLITION TO PREVENT ENEMY USE

Section I. SHIPMENT AND LIMITED STORAGE

29. Disassembly

When the transmitter is part of a set, refer to the appropriate manual for specific disassembly instructions. General instructions are given below.

a. Disconnect and remove any antenna tuning unit

that may be on top of the transmitter.

b. Disconnect all cabling to the equipment.

c. If the base is bolted to the floor, remove the bolts.

30. Repackaging for Shipment or Limited Storage

Section II. DEMOLITION OF MATERIEL TO PREVENT ENEMY USE

31. Authority for Demolition

Demolition of the equipment will be accomplished only upon order of the commander. The destruction procedures outlined in paragraph 32 will be used to prevent further use of the equipment.

32. Methods of Destruction

a. Smash. Smash the controls, indicators and meters, tubes, coils, capacitors, switches, transformers, gears, and sealed assemblies; use ledges,

axes, handaxes, pickaxes, hammers, crowbars, or heavy tools.

b. Cut. Cut cords and wiring; use axes, handaxes, or machetes.

c. Burn. Burn cords, wiring, and technical manuals; use gasoline, kerosene, oil, flame throwers, or incendiary grenades.

d. Bend. Bend panels, housing, and chassis.

e. Explode. If explosives are necessary, use firearms, grenades, or TNT.

f. Dispose. Bury or scatter the destroyed parts in slit trenches, foxholes, or other holes, or throw them into streams.

APPENDIX

REFERENCES

Following is a list of references applicable and available to the operator of Radio Transmister T-368 (*) /URT and Antenna Tuning Unit B-939-B:

TM 11-264B

Radio Set AN/GR-26D.

TM 11-621

Radio Set AN/GR-41.

TM 11-640A

Radio Set AN/GLQ-2.

[AG 413.44 (25 Feb 58)]

BY ORDER OF THE SECRETARIES OF THE ARMY AND THE AIR FORCE:

MAXWELL D. TAYLOR,
*General, United States Army,
Chief of Staff.*

OFFICIAL:

HERBERT M. JONES,
*Major General, United States Army,
The Adjutant General.*

THOMAS D. WHITE
Chief of Staff, United States Air Force

OFFICIAL:

J. L. TARR,
*Colonel, United States Air Force,
Director of Administrative Services.*

DISTRIBUTION:

Active Army:

ASA
CNGB
Technical Sti, DA
Technical Sty Bd
USA Arty Bd
USA Armor Bd
USA Ini Bd
USA Air Dot Bd
USA Abn & Elet Bd
USA Avn Bd
USA Armor Bd Test See
USA Air Dot Bd Teat See
USA Arctic Teat Bd
USCONARC
US ARADCOM
OS Ma] Comd
IN Comd
1dDW
Armies
Come
Div
USATC
Ft & Camp
Svc Colleges
Br Svc Sch
Gen Depots
Sig Sec. Gen Depots
Sig Depots

Fld Comd, AFSWP
Engr Maint Cen
Army Pictorial Cen
WRAMC
AFIP
AVIS
Port of Emb (OS)
Trans Terminal Comd
Army Terminals
OS Sup Agcy
USA Sig Pub Agcy
USA Sig Comm Engr Agcy
USA Comm Agey
TASSA
TASSA, Chicago Rgn Ofc
USA Sig Eqp Spt Agcy
USA White Sands Sig Agcy
Yuma Test Sta
USA Elet PG
Sig Fld plant Shops
Sig Lab
Mil Diet
JBUS1 tC
Units ore under Sol TOE:
5-348
5-500 (AA-AD)

5-501	11-557
6-315	11-587
6-817	11-692
5-545	11-697
6-558	17-51
6 6-35	17-55
11 - 7	20-45
11-15	20-46
11-18	20 47
11-17	20-300
11-18	32-51
11-57	32-55
11-95	32-56
11-98	32-500
11-99	39-51
11-117	39-61
11-127	44 7
11-128	44-12
11-500 (AA-AE)	44-101
11-537	55-201

NG: State AG; units-same as Active Army.
USAR: None.

For explanation of abbreviations used, see AR 320-60.
320-50.

☆U.S. GOVERNMENT PRINTING OFFICE: 1986 491-885/41047

RECOMMENDED CHANGES TO EQUIPMENT TECHNICAL PUBLICATIONS



THEN...JOT DOWN THE
DOPE ABOUT IT ON THIS FORM.
CAREFULLY TEAR IT OUT, FOLD IT
AND DROP IT IN THE MAIL.

SOMETHING WRONG WITH PUBLICATION

FROM: (PRINT YOUR UNIT'S COMPLETE ADDRESS)

DATE SENT

PUBLICATION NUMBER PUBLICATION DATE PUBLICATION TITLE

BE EXACT PIN-POINT WHERE IT IS				IN THIS SPACE, TELL WHAT IS WRONG AND WHAT SHOULD BE DONE ABOUT IT.
PAGE NO.	PARA- GRAPH	FIGURE NO.	TABLE NO.	

TEAR ALONG PERFORATED LINE

PRINTED NAME, GRADE OR TITLE AND TELEPHONE NUMBER

SIGN HERE

**TM 11-809-10/TO 31R2-2URT-121 RADIO TRANSMITTER T-368/URT,
T-368A/URT, AND T-368C/URT,**